



# SERIES 08-03

## Precision Snap Disc Thermostats High Temperature Surface Mounting Type



F-08-03-001  
September 2018

### FEATURES

- Ratings to 10A at 240VAC
- 100,000 Cycle Rating
- UL Component Recognized 
- CSA Certified 
- CE Compliant 
- Automatic Reset
- Tamper-Proof Preset Temperature  
Calibrated Settings from 240 to 550°F  
(116 to 288°C)

### APPLICATIONS

- Food Processing
- Ovens
- Packaging
- Copiers
- Plastic Processing



### DESCRIPTION

A positive-acting bimetal snap disc serves as the actuating element in these rugged, precision thermostats. As temperature reaches the tamper-proof predetermined set point, the disc snaps to provide rapid, positive contact action minimizing radio frequency interferences.

These UL recognized thermostats are individually calibrated and tested to meet both thermal and electrical characteristics. The single contact switch arm assembly minimizes failures due to contact contamination, while the fine silver contacts assure long life and excellent current carrying capacity. Resistance to vibration and harsh environments are additional features.

Many terminations and mounting assemblies are available to permit great flexibility in installation.

Series 08-03 units are designed for high temperature applications up to 550°F/288°C. The ceramic base materials and stainless steel cap provide excellent resistance to high temperature environments and keep the switch assembly free from dust and foreign particles.

## TEST SAMPLES

Operating samples can be supplied for application tests. A completed Fenwal Snap Disc Application Data Form is required to select and produce an operating sample.

Application Data Forms are available at [www.fenwalcontrols.com](http://www.fenwalcontrols.com) or your local Fenwal sales representative.

The following models are normally available from stock.

Normally Closed Contacts - Open on Rise				
P/N	Mounting	Terminals	Opens °F	Close °F
08-033024-019	Fixed	T7	400	360
08-033024-032	Fixed	T7	550	425
08-033024-106	Fixed	T7	500	440

## SPECIFICATIONS

### Switch Action

SPST (normally open or normally closed)

### Dielectric Strength

1500 VAC terminals to case.

### Insulation Resistance

100 Megohms minimum 500VDC.

### Vibration

MIL-STD-202D, Method 204B, 10 G's.

### Shock

MIL-STD-202D, Method 213A



Test Condition K, 30 G's, 11 millisec



**Table 1: Ranges and Tolerances**

Temperature Ranges	Tolerances		Differential (Nominal)	Ambient Range
	Open	Closed		
240-300°F	±7°F	±8°F	25°F	-50 to 600F 46 to 316C
116-148°C	±4°C	±4.5°C	14°C	
301-400°F	±10°F	±15°F	40°F	
149-204°C	±6°C	±8°C	22°C	
401-500°F	±20°F	±25°F	60°F	
205-260°C	±11°C	±14°C	33°C	
501-550°F	±25°F	±30°F	125°F	
261-288°C	±14°C	±17°C	69°C	

**Note:** Differences between customer and manufacturer temperature testing procedures and equipment can result in temperature variance.

**Table 2: Electrical Ratings (Resistive)**

120VAC	240VAC	30VDC	Cycles	Approvals
10A	10A	2A	100,000	
5A	5A			 
120VAC	120VA			

 and  units rated for AC operation only.  
U.L. File E18974, Guide XAPX2  
C.S.A. File LR 7378, Class 4823 02.

 CE682411

## OUTLINE DIMENSIONS

Table 3	
Mounting Bracket	Mounting Hardware Size
B1 - No Bracket (Cap Only)	H1 - No hardware (use B1)
B2 - Bottom Oval Flange	H4 - #6 screw for flange mounting
B6 - Stud Mounting Screw	H6 - #6 screw for stud mounting
Lead Wires (specific length)	
L1 - No Lead Wires	L4 - 250°C TGGT, 18 AWG, 300V insulation
L3 - 200°C TFE, 18 AWG, 300V insulation	
Terminals Positions	
T1 - Eyelet, opposed horizontal	T11 - Leads, opposed vertical
T2 - Eyelet, opposed vertical	T12 - Leads, parallel horizontal
T3 - Eyelet, parallel horizontal	T13 - Leads, parallel vertical
T6 - 1/4" Quick Connect, opposed horizontal	T13 - Leads, parallel vertical
T7 - 1/4" Quick Connect, opposed vertical	T14 - Vertical lead wires with epoxy filled mylar sleeve
T10 - Leads, opposed horizontal	T16 - Molded cover over epoxy with side exit.

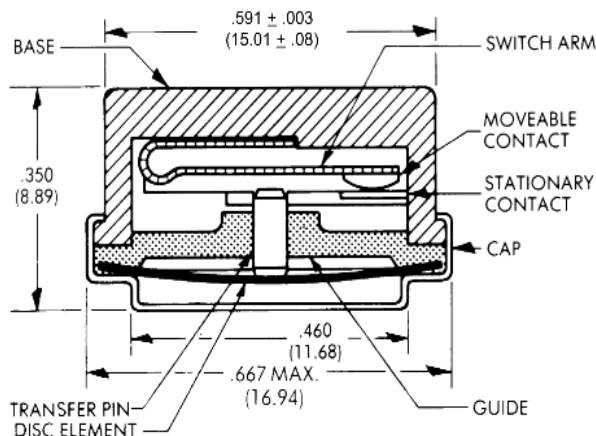

## MOUNTING BRACKETS AND MOUNTING HARDWARE SIZE

**Note:** Dimensions in brackets are in millimeters. Specifications are subject to change without notice.

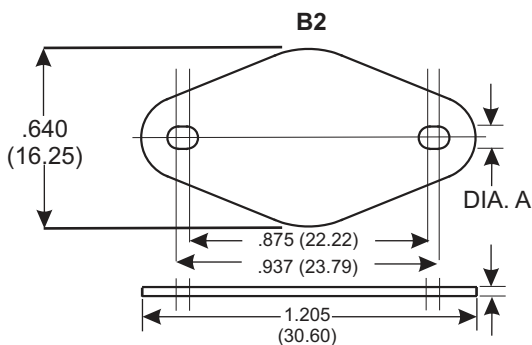

Hardware Size	Dim. A
H4	.143 (3.63)

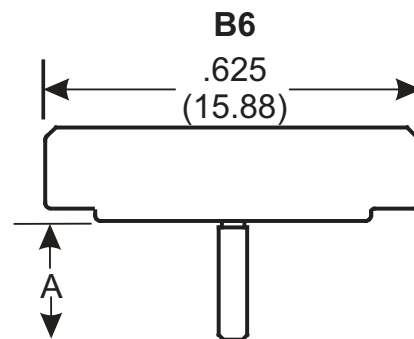

Hardware Size	Dim. A
H6	6-32 x 3/8"

## TERMINALS AND POSITIONS

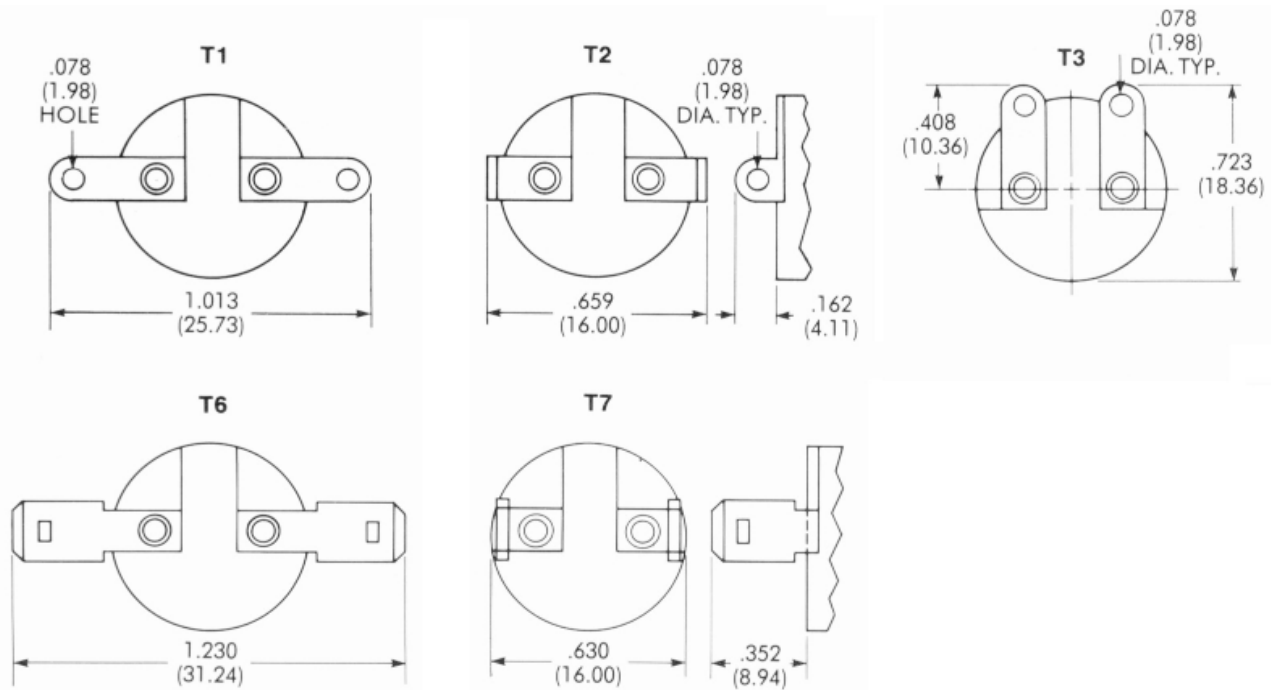

## HOW TO ORDER

To more clearly define specific requirements, please complete a Fenwal Snap Disc Application Data Form, available at [www.fenwalcontrols.com](http://www.fenwalcontrols.com) or your local Fenwal representative.

To order:

1. Specify opening and closing temperatures in degrees Fahrenheit or Celsius with tolerances; and whether the switch should open or close on temperature rise.
2. Specify terminals and mounting configurations by selecting one code number from each category in Table 3. If lead wires are required, specify length.

**EXAMPLE:** 08-03; open at 300°F, close at 275°F, B2, C3, H4, T1, L1 = Series 08-03 thermostat set to open at 300°F + 7°F on temperature rise, close at 275°F + 8°F on temperature drop. Bottom oval flange mounting bracket; stainless steel camp and mounting flange material; holes to accept #6 mounting hardware (not supplied); eyelets, opposed horizontal; no lead wires.

### EXPORT INFORMATION (USA)

Jurisdiction: EAR  
Classification: EAR99

This document contains technical data subject to the EAR.

**FENWAL**  
CONTROLS

Fenwal Controls, Kidde-Fenwal Inc.  
400 Main Street  
Ashland, MA 01721  
Tel: 800-FENWAL-1  
Fax: 508-881-7619  
[www.fenwalcontrols.com](http://www.fenwalcontrols.com)

This literature is provided for informational purposes only. KIDDE-FENWAL, INC. assumes no responsibility for the product's suitability for a particular application. The product must be properly applied to work correctly. If you need more information on this product, or if you have a particular problem or question, contact KIDDE-FENWAL, INC., Ashland, MA 01721.

# EU DECLARATION OF CONFORMITY

## We

Company Name: Kidde-Fenwal Inc.  
Postal Address: 400 Main Street  
City and Post Code: Ashland, MA 01721  
Tel: 508-881-2000

## Declare that the DoC is issued under sole responsibility and belongs to the following product:

Apparatus Model(s) Series 08-02 & 08-03 and 08-80 & 08-81  
Type: Fitting  
Batch Number Date code and Revision Level Assigned per production lot, (YYWW RR)

## Object of the Declaration:

Series 08-02 & 08-03 Surface Mount Bimetal Thermostats  
Series 08-80 & 08-81 Probe Mount Bimetal Thermostats

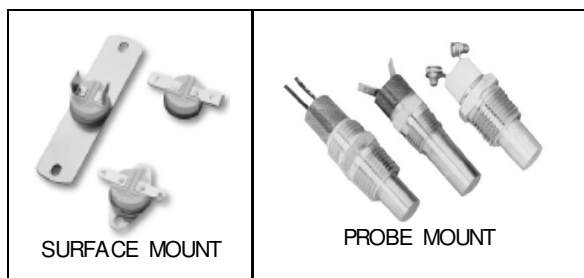

## The object of the declaration described above is in conformity within the relevant union harmonization legislation:

Gas Appliance Regulation:	(EU) 2016/426	Low Voltage Directive:	2014/35/EC
EMC Directive:	2014/30/EC	Rohs	2011/65/EU

## The following harmonized standards and technical specifications have been applied:

<u>EN 60730-1:2000:A2:2008</u>	Automatic Electrical controls for Household and Similar use.
<u>A11: 2002, A12: 2003,</u>	Part 1 General Requirements
<u>A13: 2004, A15: 2005,</u>	
<u>A15: 2007, A16: 2007 Cor. 1&amp;2</u>	
<u>EN 60730-2-9:2010</u>	Automatic Electrical controls for Household and Similar use
	Part 2-9 Particular requirements for Temperature Sensing Controls

Name of Notified Body & Number: BSI Group, 0086, EU Type Examination Certification

Notified Body Certificate No.: Series 08-02 & 08-03: CE682411  
Series 08-80 & 08-81: CE682409

Surveillance Audit Notified Body: BSI Group

For copies of the Installation Instructions and the EU DoC, got to [www.Fenwal.com](http://www.Fenwal.com), - Document Library - Data sheets.

*Paul Finn*

Kidde-Fenwal, Inc. Ashland, MA USA  
Place of Issue:

6 April 2018  
Date of Issue

Paul Finn, Certification Engineer  
Name