

Tubular and Process Assemblies

Quick Ship

On stock chart units:

- Five to seven working days on all Assembly Stock heaters
- 10 working days on special voltages and/or wattages
- 15 working days on special element lengths

Circulation Heaters

Circulation heaters provide a ready-made means to install electric heating with a minimal amount of time and labor. This is accomplished by combining heating elements, vessel, insulation, terminal enclosure, mounting brackets and inlet and outlet connections into a complete assembly.

Made from NPT screw plug or ANSI flange heater assemblies mated with a pressure vessel (tank), circulation heaters are designed to heat forced-circulation air, gases or liquids. Ideal for either in-line or side-arm operations, these assemblies direct fluids past FIREBAR® or WATROD heating elements, to deliver fast response and even heat distribution.

Watlow can meet virtually all your circulation heater assembly needs with made-to-order units. Made-to-order units can be made from a wide range of heating element sheath materials, wattages, vessel sizes and materials, pressure ratings, terminal enclosures and controls.

Performance Capabilities

- Watt densities to 120 W/in² (18.6 W/cm²)
- Wattages to one megawatt
- UL® and CSA component recognition to 480V~(ac) and 600V~(ac) respectively
- Ratings to 600 lb pressure class
- Incoloy® sheath temperatures to 1600°F (870°C)
- Passivated 316 stainless steel sheath temperatures to 1200°F (650°C)
- Steel sheath temperatures to 750°F (400°C)
- Copper sheath temperatures to 350°F (175°C)



Features and Benefits

- **Standard screw plugs and flanges** feature a wide selection of WATROD and FIREBAR elements to meet specific application requirements.

Type	Sizes (inch)
NPT Screw Plugs	1¼, 2½
ANSI flanges	3, 4, 5, 6, 8, 10, 12, 14

- **Flange ratings meet recognized agency standards.** ANSI B16.5 Class 150 on:
 - Four or six inch FIREBAR element flanges
 - Three to 14 inch WATROD element flanges
- **FIREBAR assemblies** pack more wattage in a smaller heater bundle—replaces larger flanges with round tubular elements, with a smaller package.
- **Compacted MgO insulation filled elements** maximize dielectric strength, heat transfer and life.
- **One inch (25 mm) thermal insulation**, rated to 750°F (400°C), reduces heat loss from the vessel.

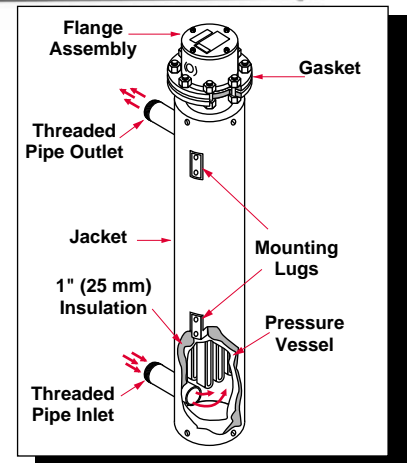

- **Heavy-gauge steel jacket (shroud)** protects thermal insulation and heating vessel. Comes with protective primer coating.
- **All catalog units rated to ANSI pressure Class 150.** Pressure vessels (tanks) are either carbon or 316 stainless steel.
- **NPT or ANSI Class 150 nozzle connections** make installation easy. Inlet and outlet nozzle connections are:
 - Threaded MNPT on eight inch and smaller tanks
 - Class 150 flanged connections on 10 inch and larger tanks

Circulation Heaters

UL® is a registered trademark of Underwriter's Laboratories, Inc.
Incoloy® is a registered trademark of Special Metals Corporation.

Tubular and Process Assemblies

Circulation Heaters

Features and Benefits

- **Mounting lugs** are welded onto the tank wall of all 2 1/2 inch NPT and larger units. Lugs are flush with outer insulation jacket and provide mounting support.
- **Flange mounting holes** straddle centerline to comply with industry standards.
- **Standard, general purpose (NEMA 1) terminal enclosures** offer easy access to terminal wiring.
- **UL® and CSA component recognition** under file numbers E52951 and 31388 respectively. See **pages 268 to 271** for details.
- **Branch circuits** are subdivided by National Electric Code (NEC) requirements to a maximum of 48 amps per circuit.

Applications

- Water:
 - Deionized
 - Demineralized
 - Clean
 - Potable
 - Process
- Industrial water rinse tanks
- Hydraulic oil, crude, asphalt
- Lubricating oils at API specified watt densities
- Heat transfer oil
- Paraffin
- Caustic cleaners
- Nitrogen, hydrogen and other air/gas systems
- Superheating steam

Options

Terminal Enclosures

General purpose (NEMA 1) terminal enclosures, without thermostats, are supplied on all Watlow circulation heaters. Moisture and explosion resistant ratings are available to meet specific application needs. For screw plug terminal enclosures,

refer to **pages 322 to 324**. For flange terminal enclosures, refer to **pages 340 to 341**.

Stand-off Terminal Enclosures

Stand-off terminal enclosures help protect terminal enclosures against excessive temperatures. For details, refer to **page 340**.

CSA Certified Enclosures

To meet agency recognition requirements, CSA certified moisture and/or explosion resistant terminal enclosures are available. Consult your Watlow representative for details.

Thermostats

To provide process temperature control, Watlow offers optional single and double pole thermostats.

Thermostats are typically mounted in the terminal enclosure. Optional side mounting on vessel also available.

See **Screw Plug Immersion Heaters, page 324**, and **Flange Immersion Heaters, on page 342** for details.

Thermocouples

To sense process or element sheath temperature, ASTM Type J or K thermocouples are available.

See **Screw Plug Immersion Heaters, page 325** and **Flange Immersion Heaters, on page 342** for details.

Process Thermocouple in Nozzle

(Must specify which nozzle)

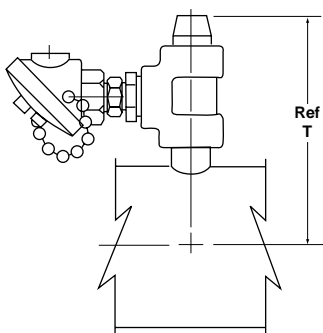

Ref. Tank Size	Ref. Nozzle Size	Dimension "A"
1 1/4	3/4 NPT	8 3/16
2 1/2	1 NPT	8 3/16
3	1 NPT	8 3/16
4	1 1/2 NPT	10 3/16
5	2 NPT	11 1/16
6	2 1/2 NPT	13 3/16
8	2 1/2 NPT	14 3/16

For 10 inch and larger tanks consult factory for dimension.

Tubular and Process Assemblies

Circulation Heaters

Options

Continued

Branch Circuits

Branch circuits are subdivided by National Electrical Code (NEC) requirements to a maximum of

48 amps per circuit. Consult factory for circuit requirements other than those listed in the stock charts.

Wattages and Voltages

Watlow routinely supplies circulation heaters with 120 to 480V~(ac) as well as wattages from 500 watts to one megawatt. If required, Watlow will configure circulation heaters

with voltages and wattages outside these parameters.

For more information on special voltage and wattage configurations, consult your Watlow representative.

Sheath Materials

The following sheath materials are available on WATROD and FIREBAR heating elements:

Standard Sheath Materials

WATROD	Incoloy® 316 stainless steel Steel Copper
FIREBAR	Incoloy®

Made-to-Order Sheath Materials

WATROD	304 stainless steel Monel®
FIREBAR	304 stainless steel

Exotic Sheath Materials

Consult your Watlow representative for details and availability.

Baffles

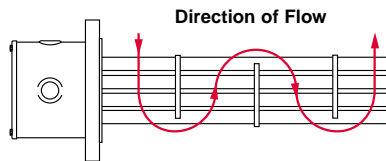

Baffles mounted on the heating element bundle enhance and/or modify liquid or gas flow for better heat transfer.

For critical sheath temperature and low flow conditions, baffles may be required.

Consult your Watlow representative for details.

Pressure Vessels

All standard pressure vessel (tank) materials are rated to 150 lb and made from:

- Carbon steel
- 316 stainless steel

All catalog pressure vessels (tanks) are steel unless otherwise noted.

316 stainless steel pressure vessels (tanks) are passivated on all wetted surfaces. Available from Assembly Stock on 2½ inch NPT and four or six inch ANSI flange circulation heaters.

Made-to-order units can be made in a variety of materials, flange sizes and pressure classes.

To order, specify **pressure vessel (tank) size, material and pressure class.**

ANSI ratings to 600 lb are available for high-pressure applications. For pressure class ratings above 600 lb, as well as other vessel materials, consult Watlow Process Systems in Troy, Missouri.

Passivated Finish

For critical applications, passivation will remove free iron from all wetted surfaces.

Consult factory for details.

Monel® is a registered trademark of Special Metals Corporation.

Tubular and Process Assemblies

Circulation Heaters

Options

Continued

Gaskets

Rubber, asbestos-free and spiral wound gaskets are available for all heater flange, and inlet and outlet flange sizes.

Watlow recommends ordering spares in case replacement becomes necessary.

To order, specify **gasket type, flange size/rating** and **process operating temperature**.

For details on gasket materials and temperature ratings, see **page 343**.

Inlet and Outlet Nozzle Connections

All inlet and outlet materials are compatible with the pressure vessel material and pressure class rating.

Vessel sizes from 1¼ to eight inches are typically configured with MNPT (Male National Pipe Thread) nozzles. Optional NPT and flange sizes can be supplied to mate with existing piping.

10 inch and larger vessels are supplied with Class 150 inlet and outlet flanges. Optional Class 300 or Class 600 can be provided to mate with existing piping.

To order, specify **type, size** and **pressure class** rating for both inlet and outlet nozzle/flange connections.

High Temperature Thermal Insulation

To further minimize heat loss, the pressure vessel's standard one inch thermal insulation wrap may be replaced with thicker or higher temperature insulation. For more information, consult your Watlow representative.

To order, specify **insulation thickness, standard** or **high temperature insulation** and **temperature rating**.

Vessels may be supplied with a primer coating without insulation.

To order, specify **no insulation**.

Protective Steel Jacket (Shroud)

To protect circulation heaters from weather or wash-down conditions, fully welded (weatherproof) or partially welded (standard) outer protective steel jackets are available. Standard steel, or made-to-order 304 or 316 stainless steel

can be supplied. Jacket diameter is dependent upon thermal insulation thickness.

To order, specify **protective steel jacket, material type** and **weatherproof**, if desired.

Support Saddles

To mate with an existing installation, customized support saddle(s) and/or mounting lugs are available.

To order, specify **mounting lugs** or **support saddles** and supply a dimensional drawing.

Tubular and Process Assemblies

Circulation Heaters

Maximum Velocities

The rate at which a gas or liquid flows through inlet and outlet pipes is critical to maintaining the desired output temperature. Pressure drop through the circulation heater must be considered to properly size blowers or pumps. The *Maximum Velocity to Avoid Excessive Pressure Drop* chart gives recommended maximum velocities, in feet per second and meters per second of gas or liquid being heated and nominal pipe size.

Maximum Velocity to Avoid Excessive Pressure Drop

Fluid	Nominal Pipe Size inch	Maximum Velocity	
		ft/sec	(m/sec)
Gases	All	200	(61.0)
Liquid	4 and smaller	10	(3.0)
Liquid	6-8	15	(5.0)
Liquid	10-12	19	(6.0)
Liquid	14-16	21	(6.4)
Liquid	18-20	23	(7.0)
Liquid	24	24	(7.3)

Vessel Orientation Guidelines

Correctly orienting the heating vessel assures lower terminal enclosure temperatures and element immersion. Detailed instructions on vessel orientation are contained in the *Installation and Maintenance Instructions* that accompanies all circulation heaters. The following are guidelines for vessel orientation in liquid and gas heating applications.

Liquids

Orient circulation heater:

- Horizontally with inlet and outlet pipes pointing up
- Vertically with the terminal enclosure up and the inlet pipe on the bottom

These orientations ensure the heating elements will be immersed at all times and help prevent premature failure.

Air or Gases

Orient circulation heater:

- Horizontally with the inlet nozzle closest to the terminal enclosure.
- Vertically with terminal enclosure at the bottom of the tank. Use the nozzle nearest the bottom as the inlet connection.

If installation constraints do not allow mounting in accordance with these guidelines, consult your Watlow representative.

Application Hints

- Select the recommended heating element sheath material and watt density for the substance being heated. Use the **Supplemental Applications Chart** on **pages 263 to 266**. If unable to determine the correct heating element type and material, consult your Watlow representative.
- Assure selecting proper vessel by considering the pressure or flow rate, process temperature and corrosiveness of the media being heated. If assistance with vessel selection is required, consult your Watlow representative.
- For maintenance/replacement procedures, retain an area twice the circulation heater's overall length to permit easy removal and inspection of screw plug or flange heater assemblies.
- Choose a FIREBAR assembly when you require:
 - A smaller package
 - More kilowatts or lower watt density in an equally sized WATROD circulation tank.
- Minimize problems associated with low flow or low liquid level conditions with a low liquid level sensor and/or sheath high-limit control.
- Ensure wiring integrity by making sure terminal enclosure temperature does not exceed 400°F (205°C).
- Protect against electrical shock by properly grounding the unit per NEC requirements.
- One or more circulation heaters may be connected in series to achieve the desired total kilowatt or temperature output.

Tubular and Process Assemblies

F.O.B.: Hannibal, Missouri

Circulation Heaters

Replacement Heater Assemblies

To help assure minimum process downtime, it's advisable to order and keep on hand a replacement flange or screw plug heater assembly.

Spare and/or replacement screw plug or flange heaters can be ordered by simply providing the

complete circulation heater code number and specifying "replacement heater only."

1 1/4" NPT

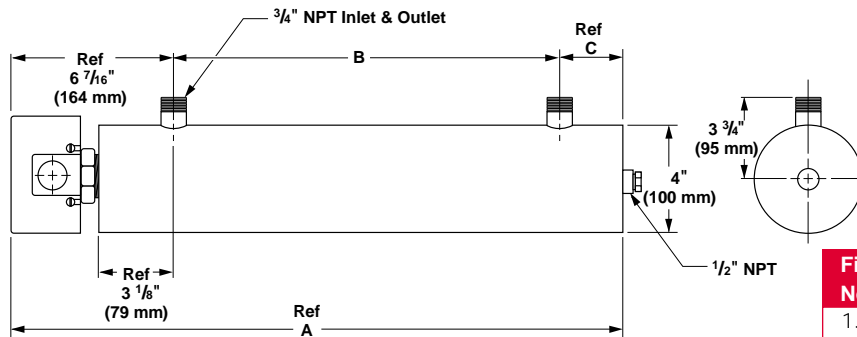

Fig. No.	A Dimension		B Dimension		C Dimension	
	in	(mm)	in	(mm)	in	(mm)
1.1	24 5/8	(625)	15	(381)	3 1/8	(79)
1.2	32 5/8	(829)	23	(584)	3	(76)
1.3	42 5/8	(1083)	32	(813)	4	(102)
1.4	63 5/8	(1616)	53	(1346)	4	(102)

1 1/4" NPT Screw Plug—WATROD Element

WATROD Description	kW	Fig. No.	Code No.		Est. Ship. Weight lbs (kg)
			120/240V~(ac) 1-Phase	240V~(ac) 1-Phase	

Application: Clean Water

60 W/in ² ④	3.0	1.1	CBEC15A6		23 (11)
Steel Tank	4.0	1.1		CBEC19A10	29 (14)
2-Copper	5.0	1.2		CBEC23J10	29 (14)
(9.3 W/cm ²)	6.0	1.2		CBEC27J10	31 (14)

Applications: Forced Air and Gases, Caustic Solutions, Degreasing Solutions

23 W/in ² ④	1.0	1.1	CBEN13G6		21 (10)
Steel Tank	1.5	1.1	CBEN19A6		29 (14)
2-Incoloy®	2.0	1.2	CBEN24G6		29 (14)
(3.6 W/cm ²)					

Applications: Lightweight Oils, Degreasing Solutions, Heat Transfer Oils

23 W/in ² ④	1.5	1.1	CBES19G6		29 (14)
Steel Tank	2.0	1.2	CBES25G6		29 (14)
2-Steel					
(3.6 W/cm ²)					

All circulation heaters are Assembly Stock unless otherwise noted.

④ Wired for higher voltage.

Availability

Assembly Stock: Five to seven working days

Standard: 10 working days

Tubular and Process Assemblies

Circulation Heaters

1¼" NPT Screw Plug—FIREBAR Element

FIREBAR Description	kW	Fig. No.	Code No.				Est. Ship. Weight	
			240V~(ac) 1-Phase	240V~(ac) 3-Phase	480V~(ac) 1-Phase	480V~(ac) 3-Phase	lbs	(kg)

Applications: Clean and Potable Water

90 W/in²® Steel Tank 1-Incoloy® (14 W/cm ²)	1.5	1.1	CBDNF7R10 ^{②⑦}		CBDNF7R11 ^{②⑦}		26	(12)
	3.0	1.1	CBDNF11G10 ^{②⑦}		CBDNF11G11 ^②		26	(12)
	5.0	1.1		CBDNF16G3		CBDNF16G5	26	(12)
	6.5	1.2		CBDNF19G3		CBDNF19G5	30	(14)
	8.5	1.2		CBDNF24L3		CBDNF24L5	31	(14)
	10.5	1.3		CBDNF29R3		CBDNF29R5	43	(20)
	12.75	1.3		CBDNF34R3		CBDNF34R5	44	(20)
	17.0	1.4		CBDNF45G3		CBDNF45G5	69	(32)
	21.5	1.4				CBDNF55R5	71	(33)

Applications: Process Water, Ethylene Glycol (50%)

45 W/in²® Steel Tank 1-Incoloy® (7 W/cm ²)	2.0	1.1		CBDNF13A27			25	(12)
	2.5	1.1		CBDNF15J27			26	(12)
	3.0	1.2		CBDNF18A27			30	(14)
	4.0	1.2		CBDNF22J27		CBDNF22J28	31	(14)
	5.0	1.3		CBDNF27J27		CBDNF27J28	43	(20)
	6.0	1.3		CBDNF32J27		CBDNF32J28	44	(20)
	8.0	1.4		CBDNF42A27		CBDNF42A28	69	(32)
	10.0	1.4		CBDNF51J27		CBDNF51J28	71	(33)

Applications: Cooking Oils, Ethylene Glycol (100%)

30 W/in²® Steel Tank 1-Incoloy® (4.7 W/cm ²)	1.7	1.1		CBDNF16G12		CBDNF16G13	26	(12)
	2.2	1.2		CBDNF19G12		CBDNF19G13	30	(14)
	2.8	1.2		CBDNF24L12		CBDNF24L13	31	(14)
	3.5	1.3		CBDNF29R12		CBDNF29R13	43	(20)
	4.25	1.3		CBDNF34R12		CBDNF34R13	44	(20)
	5.7	1.4		CBDNF45G12		CBDNF45G13	69	(32)
	7.2	1.4		CBDNF55R12		CBDNF55R13	71	(33)

Applications: Heat Transfer Oils, Lubrication Oils, Mineral Oil, Degreasing Solutions

23 W/in²® Steel Tank 1-Incoloy® (3.6 W/cm ²)	1.25	1.1		CBDNF16G20			26	(12)
	1.65	1.2		CBDNF19G20			30	(14)
	2.15	1.2		CBDNF24L20		CBDNF24L19	31	(14)
	2.65	1.3		CBDNF29R20		CBDNF29R19	43	(20)
	3.20	1.3		CBDNF34R20		CBDNF34R19	44	(20)
	4.25	1.4		CBDNF45G20		CBDNF45G19	69	(32)
	5.40	1.4		CBDNF55R20		CBDNF55R19	71	(33)

CONTINUED

All circulation heaters are Assembly Stock unless otherwise noted.

Availability

Assembly Stock: Five to seven working days

Standard: 10 working days

Truck Shipment only

② Standard

③ Must be operated 3-phase wye.

⑦ Available in 1-phase only.

⑧ Can be wired 1-phase.

Tubular and Process Assemblies

Circulation Heaters

1 1/4" NPT Screw Plug—FIREBAR Element

FIREBAR Description	kW	Fig. No.	Code No.				Est. Ship.	
			240V~(ac) 1-Phase	240V~(ac) 3-Phase	480V~(ac) 1-Phase	480V~(ac) 3-Phase	Weight lbs (kg)	

Applications: Medium Weight Oils, Heat Transfer Oils, Lube Oils, Liquid Paraffin

15 W/in ² ③	0.67	1.1		CBDNF13A29			25 (12)
Steel Tank	0.83	1.1		CBDNF15J29			26 (12)
1-Incoloy®	1.00	1.2		CBDNF18A29			30 (14)
(2.3 W/cm ²)	1.33	1.2		CBDNF22J29		CBDNF22J30	31 (14)
	1.67	1.3		CBDNF27J29		CBDNF27J30	43 (20)
	2.00	1.3		CBDNF32J29		CBDNF32J30	44 (20)
	2.67	1.4		CBDNF42A29		CBDNF42A30	69 (32)
	3.30	1.4		CBDNF51J29		CBDNF51J30	71 (33)

Applications: Bunker C and #6 Fuel Oils, Asphalt

8 W/in ² ③	0.43	1.1		CBDNF16G22			26 (12)
Steel Tank	0.55	1.2		CBDNF19G22			30 (14)
1-Incoloy®	0.70	1.2		CBDNF24L22		CBDNF24L21	31 (14)
(1.3 W/cm ²)	0.88	1.3		CBDNF29R22		CBDNF29R21	43 (20)
	1.08	1.3		CBDNF34R22		CBDNF34R21	44 (20)
	1.40	1.4		CBDNF45G22		CBDNF45G21	69 (31)
	1.80	1.4		CBDNF55R22		CBDNF55R21	71 (32)

All circulation heaters are Assembly Stock unless otherwise noted.

Truck Shipment only

③ Must be operated 3-phase wye only.

Availability

Assembly Stock: Five to seven working days

Standard: 10 working days

2 1/2" NPT

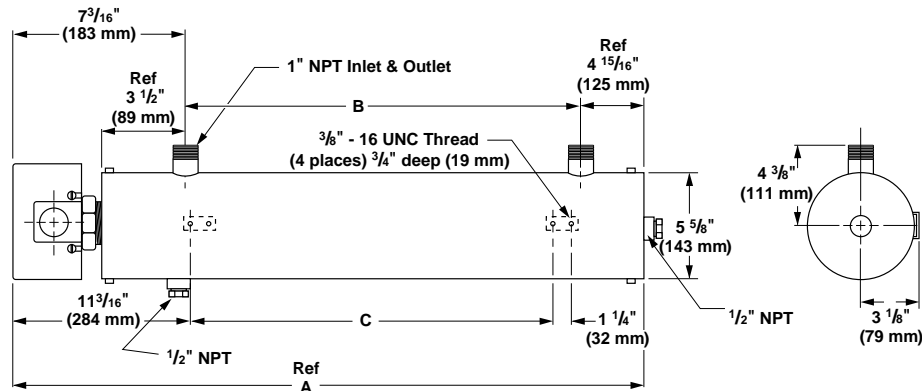

2 1/2" NPT Screw Plug

Fig. No.	A Dimension in (mm)	B Dimension in (mm)	C Dimension in (mm)
2.1	34 1/16 (881)	22 1/2 (572)	16 1/2 (419)
2.2	44 1/16 (1135)	32 1/2 (1129)	26 1/2 (673)
2.3	57 3/16 (1453)	45 (1143)	39 (991)
2.4	63 1/16 (1618)	51 1/2 (1308)	46 1/2 (1181)
2.5	34 1/16 (881)	22 1/2 (572)	16 1/2 (419)
2.6	44 1/16 (1135)	32 1/2 (1129)	26 1/2 (673)
2.7	57 3/16 (1453)	45 (1143)	39 (991)

Tubular and Process Assemblies

Circulation Heaters

2½" NPT Screw Plug—WATROD Element

WATROD Description	kW	Fig. No.	Code No.		Est. Ship. Weight	
			240V~(ac) 3-Phase	480V~(ac) 3-Phase	lbs	(kg)

Application: Clean Water

60 W/in ² Steel Tank	6.0	2.5	CBLC714L3	CBLC714L5	24	(11)
	7.5	2.5	CBLC717L3	CBLC717L5	24	(11)
3-Copper	9.0	2.5	CBLC720L3	CBLC720L5	26	(12)
(9.3 W/cm ²)	12.0	2.6	CBLC726C3	CBLC726C5	27	(13)
	15.0	2.6	CBLC731L3	CBLC731L5	29	(14)
	18.0	2.7	CBLC737C3	CBLC737C5	30	(14)

Application: Deionized Water, Demineralized Water

60 W/in ² 316 SS Tank	6.0	2.5	CBLR714L3	CBLR714L5	24	(11)
	7.5	2.5	CBLR717L3	CBLR717L5	24	(11)
3-316 SS	9.0	2.5	CBLR720L3	CBLR720L5	26	(12)
(9.3 W/cm ²)	12.0	2.6	CBLR726C3	CBLR726C5	27	(13)
Passivated	15.0	2.6	CBLR731L3	CBLR731L5	29	(14)
	18.0	2.7	CBLR737C3	CBLR737C5	30	(14)

Application: Process Water

48 W/in ² Steel Tank	6.0	2.5	CBLN717G3	CBLN717G5	24	(11)
	7.5	2.5	CBLN719R3	CBLN719R5	26	(12)
3-Incoloy®	9.0	2.5	CBLN724R3	CBLN724R5	27	(13)
(7.5 W/cm ²)	12.0	2.6	CBLN732G3	CBLN732G5	29	(14)
	15.0	2.7	CBLN739R3	CBLN739R5	31	(14)
	18.0	2.7	CBLN747G3	CBLN747G5	32	(15)

Applications: Forced Air and Gases, Caustic Solutions, Degreasing Solutions

23 W/in ² Steel Tank	3.0	2.5	CBLNA17G3	CBLNA17G5	24	(11)
	4.5	2.6	CBLNA24R3	CBLNA24R5	27	(13)
3-Incoloy®	6.0	2.6	CBLNA32G3	CBLNA32G5	29	(14)
(3.6 W/cm ²)	7.5	2.7	CBLNA39R3	CBLNA39R5	31	(14)
	9.0	2.7	CBLNA47G3	CBLNA47G5	32	(15)

Applications: Lightweight Oils, Degreasing Solutions, Heat Transfer Oils

23 W/in ² Steel Tank	3.0	2.5	CBSL717E3	CBSL717E5	24	(11)
	4.5	2.5	CBSL724N3	CBSL724N5	27	(13)
3-Steel	6.0	2.6	CBSL732E3	CBSL732E5	29	(14)
(3.6 W/cm ²)	7.5	2.7	CBSL739N3	CBSL739N5	31	(14)
	9.0	2.7	CBSL747E3	CBSL747E5	32	(15)

Applications: Medium Weight Oils, Heat Transfer Oils, Lube Oils, Liquid Paraffin

16 W/in ² Steel Tank	2.0	2.5	CBLN717G12	CBLN717G13	24	(11)
	2.5	2.5	CBLN719R12	CBLN719R13	26	(12)
3-Incoloy®	3.0	2.5	CBLN724R12	CBLN724R13	27	(13)
(2.5 W/cm ²)	4.0	2.6	CBLN732G12	CBLN732G13	29	(14)
	5.0	2.7	CBLN739R12	CBLN739R13	31	(14)
	6.0	2.7	CBLN747G12	CBLN747G13	32	(15)

Applications: Bunker C and #6 Fuel Oils

8 W/in ² Steel Tank	2.0	2.6	CBSL732E12	CBSL732E13	29	(14)
	3.0	2.7	CBSL747E12	CBSL747E13	32	(15)
3-Steel						
(1.3 W/cm ²)						

All circulation heaters are Assembly Stock unless otherwise noted.

Availability

Assembly Stock: Five to seven working days

Standard: 10 working days

③ Must be operated 3-phase wye only.

⑤ 240V~(ac) can be wired wye and operated at 480V~(ac) 3-phase to produce ½ more kW and watt density.

⑥ Can be wired wye to produce ½ of the original kW and watt density (3-phase only).

Tubular and Process Assemblies

Circulation Heaters

2½" NPT Screw Plug—FIREBAR Element

FIREBAR Description	kW	Fig. No.	Code No.		Est. Ship. Weight	
			240V~(ac) 3-Phase	480V~(ac) 3-Phase	lbs	(kg)

Applications: Clean and Potable Water

90 W/in ² ® Steel Tank 3-Incoloy® (14 W/cm ²)	15.0	2.1	CBLNF15C3	CBLNF15C5	22	(10)
	20.0	2.1	CBLNF18C3	CBLNF18C5 ^③	23	(11)
	25.0	2.1		CBLNF23C5	31	(14)
	32.0	2.2		CBLNF28L5	34	(16)
	38.0	2.2		CBLNF33L5	35	(16)

Applications: Process Water, Ethylene Glycol (50%)

45 W/in ² ® Steel Tank 3-Incoloy® (7 W/cm ²)	6.0	2.1	CBLNF12A27		21	(10)
	7.5	2.1	CBLNF14J27		22	(10)
	9.0	2.1	CBLNF17A27		23	(11)
	12.0	2.1	CBLNF21J27	CBLNF21J28	31	(14)
	15.0	2.2	CBLNF26J27	CBLNF26J28	34	(16)
	18.0	2.2	CBLNF31J27	CBLNF31J28	35	(16)
	24.0	2.3		CBLNF41A28	44	(20)
	30.0	2.4		CBLNF50J28	52	(24)

Applications: Cooking Oils, Ethylene Glycol (100%)

30 W/in ² ® Steel Tank 3-Incoloy® (4.7 W/cm ²)	5.0	2.1	CBLNF15C12	CBLNF15C13	22	(10)
	6.5	2.1	CBLNF18C12	CBLNF18C13	23	(11)
	8.5	2.1	CBLNF23C12	CBLNF23C13	31	(14)
	10.5	2.2	CBLNF28L12	CBLNF28L13	34	(16)
	12.8	2.2	CBLNF33L12	CBLNF33L13	35	(16)
	17.0	2.3	CBLNF44C12	CBLNF44C13	44	(20)
	21.5	2.4		CBLNF54L13	52	(24)

Applications: Heat Transfer Oils, Mineral Oil, Degreasing Solutions

23 W/in ² ® Steel Tank 3-Incoloy® (3.6 W/cm ²)	3.8	2.1	CBLNF15C20		22	(10)
	4.9	2.1	CBLNF18C20		23	(11)
	6.4	2.1	CBLNF23C20	CBLNF23C19	31	(14)
	7.9	2.2	CBLNF28L20	CBLNF28L19	34	(16)
	9.6	2.2	CBLNF33L20	CBLNF33L19	35	(16)
	12.8	2.3	CBLNF44C20	CBLNF44C19	44	(20)
	16.1	2.4	CBLNF54L20	CBLNF54L19	52	(24)

Applications: Medium Weight Oils, Heat Transfer Oils, Lube Oils, Liquid Paraffin

15 W/in ² ® Steel Tank 3-Incoloy® (2.3 W/cm ²)	2.0	2.1	CBLNF12A29		21	(10)
	2.5	2.1	CBLNF14J29		22	(10)
	3.0	2.1	CBLNF17A29		23	(11)
	4.0	2.1	CBLNF21J29	CBLNF21J30	31	(14)
	5.0	2.2	CBLNF26J29	CBLNF26J30	34	(16)
	6.0	2.2	CBLNF31J29	CBLNF31J30	35	(16)
	8.0	2.3	CBLNF41A29	CBLNF41A30	44	(20)
	10.0	2.4	CBLNF50J29	CBLNF50J30	52	(24)

Applications: Bunker C and #6 Fuel Oils, Asphalt

8 W/in ² ® Steel Tank 3-Incoloy® (1.3 W/cm ²)	1.25	2.1	CBLNF15C22		22	(10)
	1.63	2.1	CBLNF18C22		23	(10)
	2.13	2.1	CBLNF23C22	CBLNF23C21	31	(14)
	2.63	2.2	CBLNF28L22	CBLNF28L21	34	(15)
	3.19	2.2	CBLNF33L22	CBLNF33L21	35	(16)
	4.25	2.3	CBLNF44C22	CBLNF44C21	44	(20)
	5.38	2.4	CBLNF54L22	CBLNF54L21	52	(24)

All circulation heaters are Assembly Stock unless otherwise noted.

Availability

Assembly Stock: Five to seven working days

Standard: 10 working days

Note: Assembly Stock may be shipped same day if ordered before 11:00 am CST.

③ Must be operated 3-phase wye only.

④ Can be wired 1-phase.

Tubular and Process Assemblies

Circulation Heaters

3" Flange

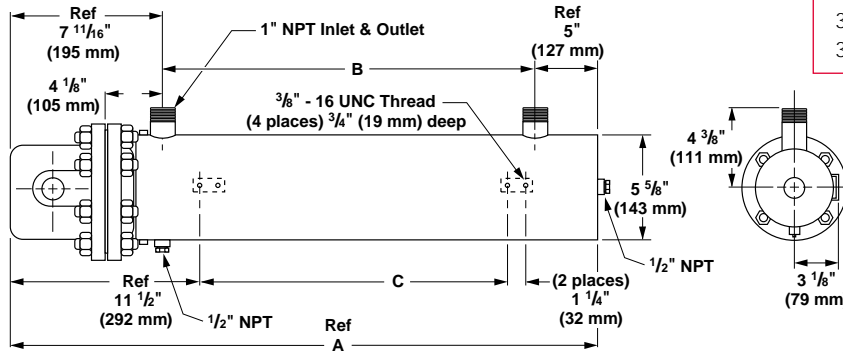

Fig. No.	A Dimension in (mm)	B Dimension in (mm)	C Dimension in (mm)
3.1	35 5/16 (894)	22 1/2 (573)	16 1/2 (419)
3.2	45 3/16 (1148)	32 1/2 (826)	26 1/2 (673)
3.3	57 1/16 (1465)	45 (1143)	39 (991)

3" 150 lb ANSI Flange—WATROD Element

WATROD Description	kW	Fig. No.	Code No.				Est. Ship. Weight lbs (kg)
			240V~(ac) 1-Phase	240V~(ac) 3-Phase	480V~(ac) 1-Phase	480V~(ac) 3-Phase	

Application: Clean Water

60 W/in ²	6.0	3.1	CFMC715J10	CFMC715J3	CFMC715J11	CFMC715J5	66 (30)
Steel Tank	9.0	3.1	CFMC721J10	CFMC721J3	CFMC721J11	CFMC721J5	70 (32)
3-Copper	12.0	3.2		CFMC727A3	CFMC727A11	CFMC727A5	80 (37)
(9.3 W/cm ²)	15.0	3.2		CFMC732J3	CFMC732J11	CFMC732J5	96 (44)
	18.0	3.3		CFMC738A3	CFMC738A11	CFMC738A5	98 (45)

Application: Process Water

48 W/in ² Ⓢ	6.0	3.1	CFMN718A10	CFMN718A3	CFMN718A11	CFMN718A5	68 (31)
Steel Tank	7.5	3.1	CFMN720J10	CFMN720J3	CFMN720J11	CFMN720J5	70 (32)
3-Incoloy®	9.0	3.2	CFMN725J10	CFMN725J3	CFMN725J11	CFMN725J5	78 (36)
(7.5 W/cm ²)	12.0	3.2		CFMN733A3	CFMN733A11	CFMN733A5	96 (44)
	15.0	3.3		CFMN740J3	CFMN740J11	CFMN740J5	100 (46)
	18.0	3.3		CFMN748A3	CFMN748A11	CFMN748A5	107 (49)

Applications: Forced Air and Gases, Caustic Solutions, Degreasing Solutions

23 W/in ² ⓈⓈ	3.0	3.1	CFMNA18A10	CFMNA18A3	CFMNA18A11	CFMNA18A5	68 (31)
Steel Tank	4.5	3.2	CFMNA25J10	CFMNA25J3	CFMNA25J11	CFMNA25J5	78 (36)
3-Incoloy®	6.0	3.2	CFMNA33A10	CFMNA33A3	CFMNA33A11	CFMNA33A5	96 (44)
(3.6 W/cm ²)	7.5	3.3	CFMNA40J10	CFMNA40J3	CFMNA40J11	CFMNA40J5	100 (46)
	9.0	3.3	CFMNA48A10	CFMNA48A3	CFMNA48A11	CFMNA48A5	107 (49)

CONTINUED

All circulation heaters are Assembly Stock unless otherwise noted.

Availability

Assembly Stock: Five to seven working days

Standard: 10 working days

■ Truck Shipment only

Ⓢ 240V~(ac) can be wired wye and operated at 480V~(ac) 3-phase to produce 1/2 more kW and watt density.

Ⓢ Can be wired wye to produce 1/2 of the original kW and watt density (3-phase only).

Tubular and Process Assemblies

Circulation Heaters

3" 150 lb ANSI Flange—WATROD Element

WATROD Description	kW	Fig. No.	Code No.				Est. Ship. Weight	
			240V~(ac) 1-Phase	240V~(ac) 3-Phase	480V~(ac) 1-Phase	480V~(ac) 3-Phase	lbs	(kg)

Applications: Lightweight Oils, Degreasing Solutions, Heat Transfer Oils

23 W/in²	3.0	3.1	CFMS718A10	CFMS718A3	CFMS718A11	CFMS718A5	68 (31)
Steel Tank	4.5	3.1	CFMS725J10	CFMS725J3	CFMS725J11	CFMS725J5	78 (36)
3-Steel	6.0	3.2	CFMS733A10	CFMS733A3	CFMS733A11	CFMS733A5	96 (44)
(3.6 W/cm ²)	7.5	3.3	CFMS740J10	CFMS740J3	CFMS740J11	CFMS740J5	100 (46)
	9.0	3.3	CFMS748A10	CFMS748A3	CFMS748A11	CFMS748A5	107 (49)

Applications: Medium Weight Oils, Heat Transfer Oils, Lube Oils, Liquid Paraffin

16 W/in²ⓐ	2.0	3.1		CFMN718A12		CFMN718A13	68 (31)
Steel Tank	2.5	3.1		CFMN720J12		CFMN720J13	70 (32)
3-Incoloy®	3.0	3.2		CFMN725J12		CFMN725J13	78 (36)
(2.6 W/cm ²)	4.0	3.2		CFMN733A12		CFMN733A13	96 (44)
	5.0	3.3		CFMN740J12		CFMN740J13	100 (46)
	6.0	3.3		CFMN748A12		CFMN748A13	107 (49)

Applications: Bunker C and #6 Fuel Oils

8 W/in²ⓐ	2.0	3.2		CFMS733A12		CFMS733A13	96 (44)
Steel Tank	3.0	3.3		CFMS748A12		CFMS748A13	107 (49)
3-Steel							
(1.3 W/cm ²)							

All circulation heaters are Assembly Stock unless otherwise noted.

ⓐ Must be operated 3-phase wye only.

Availability

Assembly Stock: Five to seven working days

Standard: 10 working days

Truck Shipment only

Tubular and Process Assemblies

Circulation Heaters

4" Flange

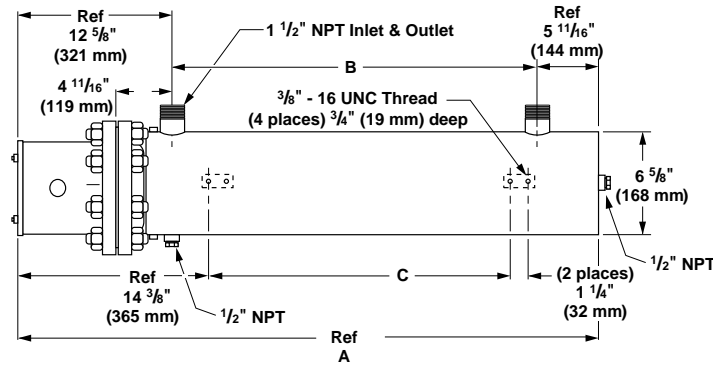
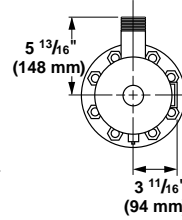

Fig. No.	A Dimension in (mm)	B Dimension in (mm)	C Dimension in (mm)
4.1	38 ¹⁵ / ₁₆ (989)	20 ¹ / ₂ (521)	17 (432)
4.2	49 ⁷ / ₁₆ (1256)	31 (787)	27 ¹ / ₂ (699)
4.3	70 ⁷ / ₁₆ (1789)	52 (1321)	48 ¹ / ₂ (1232)
4.4	91 ⁷ / ₁₆ (2326)	73 (1854)	66 (1676)



4" 150 lb ANSI Flange—WATROD Element

WATROD Description	kW	Fig. No.	Code No.								Est. Ship. Weight lbs (kg)
			240V~(ac) 1-Phase	No. of Circuits	240V~(ac) 3-Phase	No. of Circuits	480V~(ac) 1-Phase	No. of Circuits	480V~(ac) 3-Phase	No. of Circuits	

Application: Clean Water

60 W/in ² Steel Tank	12	4.1	CFOC715J10	2	CFOC715J3	1	CFOC715J11	1	CFOC715J5	1	124 (57)
	18	4.1	CFOC721J10	2	CFOC721J3	1	CFOC721J11	1	CFOC721J5	1	127 (58)
6-Copper (9.3 W/cm ²)	24	4.2	CFOC727A10	2	CFOC727A3	2	CFOC727A11	1	CFOC727A5	1	160 (73)
	30	4.2			CFOC732J3	2	CFOC732J11	2	CFOC732J5	1	163 (74)
	36	4.3			CFOC738A3	2	CFOC738A11	2	CFOC738A5	1	229 (104)
	50	4.3							CFOC751A5 ^②	2	234 (107)
60	4.4							CFOC760J5 ^②	2	297 (135)	

Application: Deionized Water, Demineralized Water

60 W/in ²	12	4.1	CFOR716A10	1	CFOR716A3	1	CFOR716A11	1	CFOR716A5	1	124 (57)
316 SS Tank	18	4.1	CFOR722A10	2	CFOR722A3	1	CFOR722A11	1	CFOR722A5	1	127 (58)
	24	4.2	CFOR727J10	2	CFOR727J3	2	CFOR727J11	1	CFOR727J5	1	160 (73)
6-316 SS (9.3 W/cm ²)	30	4.2			CFOR733A3	2	CFOR733A11	2	CFOR733A5	1	163 (74)
	36	4.3			CFOR738J3	2	CFOR738J11	2	CFOR738J5	1	229 (104)
Passivated	50	4.3							CFOR751J5	2	234 (106)
	60	4.4							CFOR761A5	2	297 (135)

Application: Process Water

48 W/in ²	9	4.1	CFON713J10	1	CFON713J3	1	CFON713J11	1	CFON713J5	1	122 (56)
Steel Tank	12	4.1	CFON718A10	2	CFON718A3	1	CFON718A11	1	CFON718A5	1	125 (57)
	15	4.1	CFON720J10	2	CFON720J3	1	CFON720J11	2	CFON720J5	1	127 (58)
6-Incoloy [®] (7.5 W/cm ²)	18	4.1	CFON725J10	2	CFON725J3	1	CFON725J11	1	CFON725J5	1	160 (73)
	24	4.2	CFON733A10	2	CFON733A3	2	CFON733A11	1	CFON733A5	1	163 (74)
30	4.3			CFON740J3	2	CFON740J11	2	CFON740J5	1	229 (104)	
36	4.3			CFON748A3	2	CFON748A11	2	CFON748A5	1	234 (107)	

CONTINUED

All circulation heaters are Assembly Stock unless otherwise noted.

② Standard

Availability

Assembly Stock: Five to seven working days

Standard: 10 working days

Truck Shipment only

Tubular and Process Assemblies

Circulation Heaters

4" 150 lb ANSI Flange—WATROD Element

WATROD Description	kW	Fig. No.	Code No.								Est. Ship.	
			240V~(ac) 1-Phase	No. of Circuits	240V~(ac) 3-Phase	No. of Circuits	480V~(ac) 1-Phase	No. of Circuits	480V~(ac) 3-Phase	No. of Circuits	lbs	(kg)

Applications: Forced Air and Gases, Caustic Solutions, Degreasing Solutions

23 W/in² Steel Tank 6-Incoloy® (3.6 W/cm ²)	6	4.1	CFONA18A10	1	CFONA18A3	1	CFONA18A11	1	CFONA18A5	1	125 (57)
	9	4.1	CFONA25J10	1	CFONA25J3	1	CFONA25J11	1	CFONA25J5	1	160 (73)
	12	4.2	CFONA33A10	2	CFONA33A3	1	CFONA33A11	1	CFONA33A5	1	163 (74)
	15	4.3	CFONA40J10	2	CFONA40J3	1	CFONA40J11	1	CFONA40J5	1	229 (104)
	18	4.3	CFONA48A10	2	CFONA48A3	1	CFONA48A11	1	CFONA48A5	1	234 (107)
	25	4.4			CFONA64J3	2	CFONA64J11	2	CFONA64J5	1	298 (136)
30	4.4			CFONA77A3	2	CFONA77A11	2	CFONA77A5	1	306 (139)	

Applications: Lightweight Oils, Degreasing Solutions, Heat Transfer Oils

23 W/in² Steel Tank 6-Steel (3.6 W/cm ²)	6	4.1	CFOS718A10	1	CFOS718A3	1	CFOS718A11	1	CFOS718A5	1	125 (57)
	9	4.1	CFOS725J10	1	CFOS725J3	1	CFOS725J11	1	CFOS725J5	1	160 (73)
	12	4.2	CFOS733A10	2	CFOS733A3	1	CFOS733A11	1	CFOS733A5	1	163 (74)
	15	4.3	CFOS740J10	2	CFOS740J3	1	CFOS740J11	1	CFOS740J5	1	229 (104)
	18	4.3	CFOS748A10	2	CFOS748A3	1	CFOS748A11	1	CFOS748A5	1	234 (107)
	25	4.4			CFOS764J3	2	CFOS764J11	2	CFOS764J5	1	298 (136)
30	4.4			CFOS777A3	2	CFOS777A11	2	CFOS777A5	1	306 (139)	

Applications: Medium Weight Oils, Heat Transfer Oils, Liquid Paraffin

16 W/in² Steel Tank 6-Incoloy® (2.6 W/cm ²)	3	4.1			CFON713J12	1			CFON713J13	1	122 (56)
	4	4.1			CFON718A12	1			CFON718A13	1	125 (57)
	5	4.1			CFON720J12	1			CFON720J13	1	127 (58)
	6	4.1			CFON725J12	1			CFON725J13	1	160 (73)
	8	4.2			CFON733A12	1			CFON733A13	1	163 (74)
	10	4.3			CFON740J12	2			CFON740J13	1	229 (104)
12	4.3			CFON748A12	1			CFON748A13	1	234 (107)	

Applications: Bunker C and #6 Fuel Oils

8 W/in² Steel Tank 6-Steel (1.3 W/cm ²)	5	4.3			CFOS740J12	1			CFOS740J13	1	229 (104)
	6	4.3			CFOS748A12	1			CFOS748A13	1	234 (106)
	8	4.4			CFOS764J12	1			CFOS764J13	1	298 (135)
	10	4.4			CFOS777A12	1			CFOS777A13	1	306 (139)

All circulation heaters are Assembly Stock unless otherwise noted.

Availability

Assembly Stock: Five to seven working days

Standard: 10 working days

Truck Shipment only

③ Must be operated 3-phase wye only.

⑤ 240V~(ac) can be wired wye and operated at 480V~(ac) 3-phase to produce ½ more kW and watt density.

⑥ Can be wired wye to produce ½ of the original kW and watt density (3-phase only).

Tubular and Process Assemblies

Circulation Heaters

4" 150 lb ANSI Flange—FIREBAR Element

FIREBAR Description	kW	Fig. No.	Code No.				Est. Ship. Weight lbs (kg)
			240V~(ac) 3-Phase	No. of Circuits	480V~(ac) 3-Phase	No. of Circuits	

Applications: Process Water, Ethylene Glycol (50%)

45 W/in ² Steel Tank 6-Incoloy® (7 W/cm ²)	12.0	4.1	CFONF13G27	1			125 (57)
	15.0	4.1	CFONF16A27	1			128 (58)
	18.0	4.1	CFONF18G27	1			130 (59)
	24.0	4.1	CFONF22R27	2	CFONF22R28	1	133 (61)
	30.0	4.2	CFONF27R27	2	CFONF27R28	1	168 (77)
	36.0	4.2	CFONF32R27	2	CFONF32R28	1	170 (78)
	48.0	4.3			CFONF42G28	2	236 (107)
	60.0	4.3			CFONF51R28	2	240 (109)

Applications: Cooking Oils, Ethylene Glycol (100%)

30 W/in ² Steel Tank 6-Incoloy® (4.7 W/cm ²)	10.0	4.1	CFONF16J12	1	CFONF16J13	1	128 (58)
	13.0	4.1	CFONF19J12	1	CFONF19J13	1	130 (59)
	17.0	4.1	CFONF24J12	1	CFONF24J13	1	133 (61)
	21.0	4.2	CFONF30A12	2	CFONF30A13	1	168 (77)
	25.5	4.2	CFONF35A12	2	CFONF35A13	1	170 (78)
	34.0	4.3	CFONF45J12	2	CFONF45J13	1	236 (107)
	43.0	4.3			CFONF56A13	2	240 (109)

Applications: Heat Transfer Oils, Mineral Oils, Degreasing Solutions

23 W/in ² ④ Steel Tank 6-Incoloy® (3.6 W/cm ²)	7.5	4.1	CFONF16J20	1			128 (58)
	10.0	4.1	CFONF19J20	1			130 (59)
	12.8	4.1	CFONF24J20	1	CFONF24J19	1	133 (61)
	15.8	4.2	CFONF30A20	1	CFONF30A19	1	168 (77)
	19.0	4.2	CFONF35A20	1	CFONF35A19	1	170 (78)
	25.0	4.3	CFONF45J20	2	CFONF45J19	1	236 (107)
	32.3	4.3	CFONF56A20	2	CFONF56A19	1	240 (109)

Applications: Medium Weight Oils, Heat Transfer Oils, Lube Oils, Liquid Paraffin

15 W/in ² ③ Steel Tank 6-Incoloy® (2.3 W/cm ²)	4.0	4.1	CFONF13G29	1			125 (57)
	5.0	4.1	CFONF16A29	1			128 (58)
	6.0	4.1	CFONF18G29	1			130 (59)
	8.0	4.1	CFONF22R29	1	CFONF22R30	1	133 (61)
	10.0	4.2	CFONF27R29	1	CFONF27R30	1	168 (77)
	12.0	4.2	CFONF32R29	1	CFONF32R30	1	170 (78)
	16.0	4.3	CFONF42G29	1	CFONF42G30	1	236 (107)
	20.0	4.3	CFONF51R29	1	CFONF51R30	1	240 (109)

Applications: Bunker C and #6 Fuel Oils, Asphalt

8 W/in ² ③ Steel Tank 6-Incoloy® (1.3 W/cm ²)	2.5	4.1	CFONF16J22	1			128 (58)
	3.25	4.1	CFONF19J22	1			130 (59)
	4.25	4.1	CFONF24J22	1	CFONF24J21	1	133 (61)
	5.25	4.2	CFONF30A22	1	CFONF30A21	1	168 (77)
	6.38	4.2	CFONF35A22	1	CFONF35A21	1	170 (77)
	8.5	4.3	CFONF45J22	1	CFONF45J21	1	236 (107)
	10.75	4.3	CFONF56A22	1	CFONF56A21	1	240 (109)

All circulation heaters are Assembly Stock unless otherwise noted.

③ Must be operated 3-phase wye only.

④ Wired for higher voltage.

Availability

Assembly Stock: Five to seven working days

Standard: 10 working days

■ Truck Shipment only

Tubular and Process Assemblies

Circulation Heaters

5" Flange

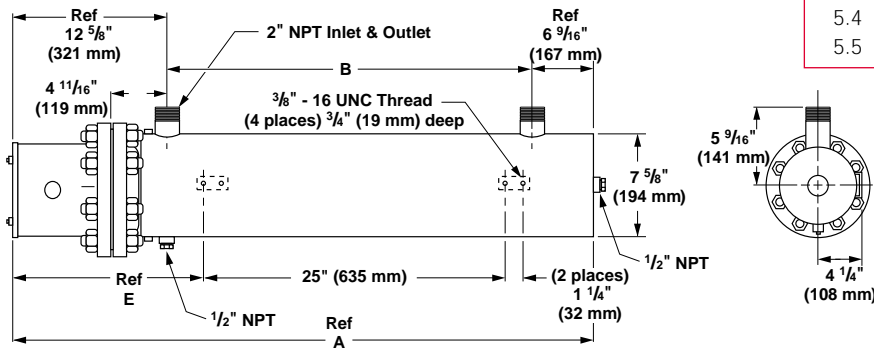

Fig. No.	A Dimension in (mm)	B Dimension in (mm)	E Dimension in (mm)
5.1	49 ³ / ₁₆ (1249)	30 (762)	14 ⁷ / ₁₆ (378)
5.2	56 ³ / ₁₆ (1427)	37 (940)	18 ³ / ₁₆ (471)
5.3	67 ¹ / ₁₆ (1719)	48 ¹ / ₂ (1232)	24 ¹⁵ / ₁₆ (633)
5.4	81 ¹ / ₁₆ (2059)	61 ⁷ / ₁₆ (1572)	30 ⁷ / ₁₆ (784)
5.5	94 ¹ / ₁₆ (2389)	74 ⁷ / ₁₆ (1902)	37 ¹⁵ / ₁₆ (964)

5" 150 lb ANSI Flange—WATROD Element

WATROD Description	kW	Fig. No.	Code No.								Est. Ship. Weight	
			240V~(ac) 1-Phase	No. of Circuits	240V~(ac) 3-Phase	No. of Circuits	480V~(ac) 1-Phase	No. of Circuits	480V~(ac) 3-Phase	No. of Circuits	lbs	(kg)

Application: Clean Water

60 W/in ² Steel Tank	24	5.1	CFNC727A10	3	CFNC727A3	2	CFNC727A11	3	CFNC727A5	1	140 (64)	
	30	5.1			CFNC732J3	2	CFNC732J11	2	CFNC732J5	1	142 (65)	
	6-Copper (9.3 W/cm ²)	36			5.2	CFNC738A3	2	CFNC738A11	2	CFNC738A5	1	160 (73)
		50			5.3					CFNC751A5	2	180 (82)
	60	5.4					CFNC760J5 ^②	2	190 (87)			
60 W/in ² Steel Tank	36	5.1			CFNC727A3X	3	CFNC727A11X	3	CFNC727A5X	1	145 (66)	
	45	5.1			CFNC732J3X	3	CFNC732J11X	3	CFNC732J5X	3	147 (67)	
	9-Copper (9.3 W/cm ²)	54	5.2			CFNC738A3X	3	CFNC738A11X	3	CFNC738A5X	3	166 (76)
		75	5.3						CFNC751A5X	3	188 (86)	
	90	5.4						CFNC760J5X ^②	3	200 (91)		

Application: Process Water

48 W/in ² ^⑤ Steel Tank	24	5.1	CFNN733A10	3	CFNN733A3	2	CFNN733A11	3	CFNN733A5	1	145 (66)	
	30	5.2			CFNN740J3	2	CFNN740J11	2	CFNN740J5	1	167 (76)	
	6-Incoloy [®] (7.5 W/cm ²)	36			5.3	CFNN748A3	2	CFNN748A11	2	CFNN748A5	1	180 (82)
48 W/in ² Steel Tank	36	5.1			CFNN733A3X	3	CFNN733A11X	3	CFNN733A5X	1	150 (68)	
	45	5.2			CFNN740J3X	3	CFNN740J11X	3	CFNN740J5X	3	173 (79)	
	9-Incoloy [®] (7.5 W/cm ²)	54	5.3			CFNN748A3X	3	CFNN748A11X	3	CFNN748A5X	3	188 (86)

CONTINUED

All circulation heaters are Assembly Stock unless otherwise noted.

Availability

Assembly Stock: Five to seven working days

Standard: 10 working days

Truck Shipment only

^② Standard

^⑤ 240V~(ac) can be wired wye and operated at 480V~(ac) 3-phase to produce 1/3 more kW and watt density.

Tubular and Process Assemblies

Circulation Heaters

5" 150 lb ANSI Flange—WATROD Element

WATROD Description	kW	Fig. No.	Code No.								Est. Ship.	
			240V~(ac) 1-Phase	No. of Circuits	240V~(ac) 3-Phase	No. of Circuits	480V~(ac) 1-Phase	No. of Circuits	480V~(ac) 3-Phase	No. of Circuits	Weight lbs	(kg)

Applications: Forced Air and Gases, Caustic Solutions, Degreasing Solutions

23 W/in²⑤ Steel Tank	9	5.1	CFNNA25J10	1	CFNNA25J3	1	CFNNA25J11	1	CFNNA25J5	1	140 (64)	
	12	5.2	CFNNA33A10	2	CFNNA33A3	1	CFNNA33A11	1	CFNNA33A5	1	145 (66)	
	6-Incoloy® (3.6 W/cm ²)	15	5.2	CFNNA40J10	2	CFNNA40J3	1	CFNNA40J11	1	CFNNA40J5	1	167 (76)
		18	5.3	CFNNA48A10	2	CFNNA48A3	1	CFNNA48A11	1	CFNNA48A5	1	180 (82)
		25	5.4			CFNNA64J3	2	CFNNA64J11	2	CFNNA64J5	1	195 (89)
		30	5.5			CFNNA77A3	2	CFNNA77A11	2	CFNNA77A5	1	220 (100)
23 W/in² Steel Tank	14	5.1	CFNNA25J10X	3	CFNNA25J3X	1	CFNNA25J11X	1	CFNNA25J5X	1	140 (66)	
	18	5.2	CFNNA33A10X	3	CFNNA33A3X	1	CFNNA33A11X	1	CFNNA33A5X	1	145 (68)	
	9-Incoloy® (3.6 W/cm ²)	23	5.2	CFNNA40J10X	3	CFNNA40J3X	3	CFNNA40J11X	1	CFNNA40J5X	1	167 (79)
		27	5.3	CFNNA48A10X	3	CFNNA48A3X	3	CFNNA48A11X	3	CFNNA48A5X	1	180 (86)
		38	5.4			CFNNA64J3X	3	CFNNA64J11X	3	CFNNA64J5X	1	195 (94)
		45	5.5			CFNNA77A3X	3	CFNNA77A11X	3	CFNNA77A5X	3	220 (106)

Applications: Lightweight Oils, Degreasing Solutions, Heat Transfer Oils

23 W/in² Steel Tank	12	5.2	CFNS733A10	2	CFNS733A3	1	CFNS733A11	1	CFNS733A5	1	145 (66)	
	15	5.2	CFNS740J10	2	CFNS740J3	1	CFNS740J11	1	CFNS740J5	1	167 (76)	
	6-Steel (3.6 W/cm ²)	18	5.3	CFNS748A10	2	CFNS748A3	3	CFNS748A11	1	CFNS748A5	1	180 (82)
		25	5.4			CFNS764J3	2	CFNS764J11	2	CFNS764J5	1	195 (89)
		30	5.5			CFNS777A3	2	CFNS777A11	2	CFNS777A5	1	220 (100)
23 W/in² Steel Tank	18	5.2	CFNS733A10X	3	CFNS733A3X	1	CFNS733A11X	1	CFNS733A5X	1	150 (68)	
	23	5.2	CFNS740J10X	3	CFNS740J3X	3	CFNS740J11X	1	CFNS740J5X	1	173 (79)	
	9-Steel (3.6 W/cm ²)	27	5.3	CFNS748A10X	3	CFNS748A3X	1	CFNS748A11X	3	CFNS748A5X	1	188 (86)
		38	5.4			CFNS764J3X	3	CFNS764J11X	3	CFNS764J5X	1	206 (94)
		45	5.5			CFNS777A3X	3	CFNS777A11X	3	CFNS777A5X	3	233 (106)

Applications: Medium Weight Oils, Heat Transfer Oils, Liquid Paraffin

16 W/in²③ Steel Tank	8	5.1			CFNN733A12	1			CFNN733A13	1	145 (66)
	10	5.2			CFNN740J12	1			CFNN740J13	1	167 (76)
	12	5.3			CFNN748A12	1			CFNN748A13	1	180 (82)
16 W/in²③ Steel Tank	12	5.1			CFNN733A12X	1			CFNN733A13X	1	150 (68)
	15	5.2			CFNN740J12X	1			CFNN740J13X	1	173 (79)
	18	5.3			CFNN748A12X	1			CFNN748A13X	1	188 (86)

Applications: Bunker C and #6 Fuel Oils

8 W/in²③ Steel Tank	5	5.2			CFNS740J12	1			CFNS740J13	1	167 (76)	
	6	5.3			CFNS748A12	1			CFNS748A13	1	180 (82)	
	6-Steel (1.3 W/cm ²)	8	5.4			CFNS764J12	1			CFNS764J13	1	195 (89)
		10	5.5			CFNS777A12	1			CFNS777A13	1	220 (100)
8 W/in²③ Steel Tank	7.5	5.2			CFNS740J12X	1			CFNS740J13X	1	173 (79)	
	9	5.3			CFNS748A12X	1			CFNS748A13X	1	188 (86)	
	9-Steel (1.3 W/cm ²)	12	5.4			CFNS764J12X	1			CFNS764J13X	1	206 (94)
		15	5.5			CFNS777A12X	1			CFNS777A13X	1	233 (106)

All circulation heaters are Assembly Stock unless otherwise noted.

Availability

Assembly Stock: Five to seven working days

Standard: 10 working days

■ Truck Shipment only

③ Must be operated 3-phase wye only.

⑤ 240V~(ac) can be wired wye and operated at 480V~(ac) 3-phase to produce ½ more kW and watt density.

⑥ Can be wired wye to produce ⅓ of the original kW and watt density (3-phase only).

Tubular and Process Assemblies

Circulation Heaters

6" Flange

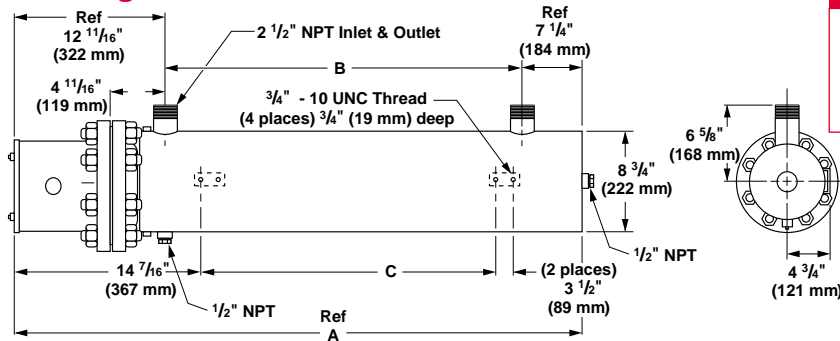

Fig. No.	A Dimension in (mm)	B Dimension in (mm)	C Dimension in (mm)
6.1	40 ⁷ / ₁₆ (1027)	20 ¹ / ₂ (521)	17 (432)
6.2	50 ¹⁵ / ₁₆ (1294)	31 (787)	27 ¹ / ₂ (699)
6.3	71 ¹⁵ / ₁₆ (1827)	52 (1321)	48 ¹ / ₂ (1232)
6.4	92 ¹⁵ / ₁₆ (2361)	73 (1854)	66 (1676)

6" 150 lb ANSI Flange—WATROD Element

WATROD Description	kW	Fig. No.	Code No.								Est. Ship.	
			240V~(ac) 1-Phase	No. of Circuits	240V~(ac) 3-Phase	No. of Circuits	480V~(ac) 1-Phase	No. of Circuits	480V~(ac) 3-Phase	No. of Circuits	Weight lbs	(kg)

Application: Clean Water

60 W/in ² Steel Tank 12-Copper (9.3 W/cm ²)	24	6.1	CFPC715G10	3	CFPC715G3	2	CFPC715G11	2	CFPC715G5	1	212 (97)
	36	6.1	CFPC721G10	4	CFPC721G3	2	CFPC721G11	2	CFPC721G5	1	217 (99)
	48	6.2			CFPC726R3	4	CFPC726R11	3	CFPC726R5	2	222 (101)
	60	6.2			CFPC732G3	4	CFPC732G11	3	CFPC732G5	2	226 (103)
	72	6.3			CFPC737R3	4			CFPC737R5	2	290 (132)
	100	6.3							CFPC750R5	4	298 (136)
120	6.4							CFPC760G5	4	360 (164)	
60 W/in ² Steel Tank 15-Copper (9.3 W/cm ²)	30	6.1	CFPC715G10X	3	CFPC715G3X	5	CFPC715G11X	3	CFPC715G5X	1	215 (98)
	45	6.1	CFPC721G10X	5	CFPC721G3X	5	CFPC721G11X	3	CFPC721G5X	5	223 (102)
	60	6.2			CFPC726R3X	5	CFPC726R11X	3	CFPC726R5X	5	226 (103)
	75	6.2			CFPC732G3X	5	CFPC732G11X	5	CFPC732G5X	5	288 (131)
	90	6.3			CFPC737R3X	5			CFPC737R5X	5	296 (134)
	125	6.3							CFPC750R5X	5	306 (139)
150	6.4							CFPC760G5X [®]	5	370 (168)	

Application: Deionized Water, Demineralized Water

60 W/in ² 316 SS Tank 12-316 SS (9.3 W/cm ²)	24	6.1	CFPR715N10	3	CFPR715N3	2	CFPR715N11	2	CFPR715N5	1	212 (97)
	36	6.1	CFPR721N10	4	CFPR721N3	2	CFPR721N11	3	CFPR721N5	1	217 (99)
	48	6.2			CFPR727E3	4	CFPR727E11	3	CFPR727E5	2	222 (101)
	60	6.2			CFPR732N3	4	CFPR732N11	3	CFPR732N5	2	226 (103)
	72	6.3			CFPR738E3	4			CFPR738E5	2	290 (132)
	100	6.3							CFPR751E5	4	298 (136)
120	6.4							CFPR760N5	4	360 (164)	
60 W/in ² 316 SS Tank 15-316 SS (9.3 W/cm ²)	30	6.1	CFPR715N10X	3	CFPR715N3X	5	CFPR715N11X	3	CFPR715N5X	1	215 (98)
	45	6.1	CFPR721N10X	5	CFPR721N3X	5	CFPR721N11X	3	CFPR721N5X	5	223 (102)
	60	6.2			CFPR727E3X	5	CFPR727E11X	3	CFPR727E5X	5	226 (103)
	75	6.2			CFPR732N3X	5	CFPR732N11X	5	CFPR732N5X	5	288 (131)
	90	6.3			CFPR738E3X	5			CFPR738E5X	5	296 (135)
	125	6.3							CFPR751E5X	5	306 (139)
150	6.4							CFPR760N5X	5	370 (168)	

CONTINUED

All circulation heaters are Assembly Stock unless otherwise noted. © Standard

Availability

Assembly Stock: Five to seven working days

Standard: 10 working days

Truck Shipment only

Tubular and Process Assemblies

Circulation Heaters

6" 150 lb ANSI Flange—WATROD Element

WATROD Description	kW	Fig. No.	Code No.								Est. Ship.	
			240V~(ac) 1-Phase	No. of Circuits	240V~(ac) 3-Phase	No. of Circuits	480V~(ac) 1-Phase	No. of Circuits	480V~(ac) 3-Phase	No. of Circuits	Weight lbs	(kg)

Application: Process Water

48 W/in² Steel Tank 12-Incoloy® (7.5 W/cm ²)	18	6.1	CFPN713G10	2	CFPN713G3	1	CFPN713G11	1	CFPN713G5	1	212 (97)
	24	6.1	CFPN717R10	3	CFPN717R3	2	CFPN717R11	2	CFPN717R5	1	214 (97)
	30	6.1	CFPN720G10	3	CFPN720G3	2	CFPN720G11	2	CFPN720G5	1	217 (99)
	36	6.1	CFPN725G10	4	CFPN725G3	2	CFPN725G11	2	CFPN725G5	1	222 (101)
	48	6.2			CFPN732R3	4	CFPN732R11	3	CFPN732R5	2	226 (103)
	60	6.3			CFPN740G3	4	CFPN740G11	3	CFPN740G5	2	290 (132)
	72	6.3			CFPN747R3	4			CFPN747R5	2	298 (136)
48 W/in² Steel Tank 15-Incoloy® (7.5 W/cm ²)	23	6.1	CFPN713G10X	3	CFPN713G3X	5	CFPN713G11X	1	CFPN713G5X	1	215 (98)
	30	6.1	CFPN717R10X	3	CFPN717R3X	5	CFPN717R11X	3	CFPN717R5X	1	217 (99)
	38	6.1	CFPN720G10X	5	CFPN720G3X	5	CFPN720G11X	3	CFPN720G5X	1	223 (102)
	45	6.1	CFPN725G10X	5	CFPN725G3X	5	CFPN725G11X	3	CFPN725G5X	5	226 (103)
	60	6.2			CFPN732R3X	5	CFPN732R11X	3	CFPN732R5X	5	288 (131)
	75	6.3			CFPN740G3X	5	CFPN740G11X	5	CFPN740G5X	5	296 (135)
	90	6.3			CFPN747R3X	5			CFPN747R5X	5	306 (139)

Circulation Heaters

Applications: Forced Air and Gases, Caustic Solutions, Degreasing Solutions

23 W/in² Steel Tank 12-Incoloy® (3.6 W/cm ²)	12	6.1	CFPNA17R10	2	CFPNA17R3	1	CFPNA17R11	1	CFPNA17R5	1	214 (97)
	18	6.1	CFPNA25G10	2	CFPNA25G3	1	CFPNA25G11	1	CFPNA25G5	1	222 (101)
	24	6.2	CFPNA32R10	3	CFPNA32R3	2	CFPNA32R11	2	CFPNA32R5	1	226 (103)
	30	6.3	CFPNA40G10	3	CFPNA40G3	2	CFPNA40G11	2	CFPNA40G5	1	290 (132)
	36	6.3	CFPNA47R10	4	CFPNA47R3	2	CFPNA47R11	2	CFPNA47R5	1	298 (136)
	50	6.4			CFPNA64G3	4	CFPNA64G11	3	CFPNA64G5	2	360 (164)
	60	6.4			CFPNA76R3	4	CFPNA76R11	3	CFPNA76R5	2	368 (167)
23 W/in² Steel Tank 15-Incoloy® (3.6 W/cm ²)	15	6.1	CFPNA17R10X	3	CFPNA17R3X	1	CFPNA17R11X	1	CFPNA17R5X	1	217 (99)
	23	6.1	CFPNA25G10X	3	CFPNA25G3X	5	CFPNA25G11X	1	CFPNA25G5X	1	226 (103)
	30	6.2	CFPNA32R10X	3	CFPNA32R3X	5	CFPNA32R11X	3	CFPNA32R5X	1	288 (131)
	38	6.3	CFPNA40G10X	5	CFPNA40G3X	5	CFPNA40G11X	3	CFPNA40G5X	1	296 (135)
	45	6.3	CFPNA47R10X	5	CFPNA47R3X	5	CFPNA47R11X	3	CFPNA47R5X	5	306 (139)
	63	6.4			CFPNA64G3X	5	CFPNA64G11X	3	CFPNA64G5X	5	370 (168)
	75	6.4			CFPNA76R3X	5	CFPNA76R11X	5	CFPNA76R5X	5	381 (173)

CONTINUED

All circulation heaters are Assembly Stock unless otherwise noted.

Availability

Assembly Stock: Five to seven working days

Standard: 10 working days

Truck Shipment only

- ⑤ 240V~(ac) can be wired wye and operated at 480V~(ac) 3-phase to produce ½ more kW and watt density.
- ⑥ Can be wired wye to produce ½ of the original kW and watt density (3-phase only).

Tubular and Process Assemblies

Circulation Heaters

6" 150 lb ANSI Flange—WATROD Element

WATROD Description	kW	Fig. No.	Code No.								Est. Ship.	
			240V~(ac) 1-Phase	No. of Circuits	240V~(ac) 3-Phase	No. of Circuits	480V~(ac) 1-Phase	No. of Circuits	480V~(ac) 3-Phase	No. of Circuits	Weight lbs	(kg)

Applications: Lightweight Oils, Degreasing Solutions, Heat Transfer Oils

23 W/in² Steel Tank 12-Steel (3.6 W/cm ²)	12	6.1	CFPS717R10	2	CFPS717R3	1	CFPS717R11	1	CFPS717R5	1	214 (97)
	18	6.1	CFPS725G10	2	CFPS725G3	1	CFPS725G11	1	CFPS725G5	1	222 (101)
	24	6.2	CFPS732R10	3	CFPS732R3	2	CFPS732R11	2	CFPS732R5	1	226 (103)
	30	6.3	CFPS740G10	3	CFPS740G3	2	CFPS740G11	2	CFPS740G5	1	290 (132)
	36	6.3	CFPS747R10	4	CFPS747R3	2	CFPS747R11	2	CFPS747R5	1	298 (136)
	50	6.4			CFPS764G3	4	CFPS764G11	3	CFPS764G5	2	360 (164)
60	6.4			CFPS776R3	4	CFPS776R11	3	CFPS776R5	2	368 (167)	
23 W/in² Steel Tank 15-Steel (3.6 W/cm ²)	15	6.1	CFPS717R10X	3	CFPS717R3X	1	CFPS717R11X	1	CFPS717R5X	1	217 (99)
	23	6.1	CFPS725G10X	3	CFPS725G3X	5	CFPS725G11X	1	CFPS725G5X	1	226 (103)
	30	6.2	CFPS732R10X	3	CFPS732R3X	5	CFPS732R11X	3	CFPS732R5X	1	288 (131)
	38	6.3	CFPS740G10X	5	CFPS740G3X	5	CFPS740G11X	3	CFPS740G5X	1	296 (135)
	45	6.3	CFPS747R10X	5	CFPS747R3X	5	CFPS747R11X	3	CFPS747R5X	5	306 (139)
	63	6.4			CFPS764G3X	5	CFPS764G11X	3	CFPS764G5X	5	370 (168)
75	6.4			CFPS776R3X	5	CFPS776R11X	5	CFPS776R5X	5	381 (173)	

Applications: Medium Weight Oils, Heat Transfer Oils, Liquid Paraffin

16 W/in² Steel Tank 12-Incoloy® (2.6 W/cm ²)	6	6.1			CFPN713G12	1			CFPN713G13	1	212 (97)
	8	6.1			CFPN717R12	1			CFPN717R13	1	214 (97)
	10	6.1			CFPN720G12	1			CFPN720G13	1	217 (99)
	12	6.1			CFPN725G12	1			CFPN725G13	1	222 (101)
	16	6.2			CFPN732R12	1			CFPN732R13	1	226 (103)
	20	6.3			CFPN740G12	2			CFPN740G13	1	290 (132)
24	6.3			CFPN747R12	2			CFPN747R13	1	298 (136)	
16 W/in² Steel Tank 15-Incoloy® (2.6 W/cm ²)	7.5	6.1			CFPN713G12X	1			CFPN713G13X	1	215 (98)
	10	6.1			CFPN717R12X	1			CFPN717R13X	1	217 (99)
	12.5	6.1			CFPN720G12X	1			CFPN720G13X	1	223 (102)
	15	6.1			CFPN725G12X	1			CFPN725G13X	1	226 (103)
	20	6.2			CFPN732R12X	5			CFPN732R13X	1	288 (131)
	25	6.3			CFPN740G12X	5			CFPN740G13X	1	296 (135)
30	6.3			CFPN747R12X	5			CFPN747R13X	1	306 (139)	

Applications: Bunker C and #6 Fuel Oils

8 W/in² Steel Tank 12-Steel (1.3 W/cm ²)	8	6.2			CFPS732R12	1			CFPS732R13	1	226 (103)
	10	6.3			CFPS740G12	1			CFPS740G13	1	290 (132)
	12	6.3			CFPS747R12	1			CFPS747R13	1	298 (136)
	16.5	6.4			CFPS764G12	1			CFPS764G13	1	360 (164)
	20	6.4			CFPS776R12	1			CFPS776R13	1	368 (167)
8 W/in² Steel Tank 15-Steel (1.3 W/cm ²)	10	6.2			CFPS732R12X	1			CFPS732R13X	1	288 (131)
	12.5	6.3			CFPS740G12X	1			CFPS740G13X	1	296 (135)
	15	6.3			CFPS747R12X	1			CFPS747R13X	1	306 (139)
	21	6.4			CFPS764G12X	5			CFPS764G13X	1	370 (168)
	25	6.4			CFPS776R12X	5			CFPS776R13X	1	381 (173)

All circulation heaters are Assembly Stock unless otherwise noted.

③ Must be operated 3-phase wye only.

Availability

Assembly Stock: Five to seven working days

Standard: 10 working days

Truck Shipment only

Tubular and Process Assemblies

Circulation Heaters

6" 150 lb ANSI Flange—FIREBAR Element

FIREBAR Description	kW	Fig. No.	Code No.				Est. Ship. Weight lbs (kg)
			240V~(ac) 3-Phase	No. of Circuits	480V~(ac) 3-Phase	No. of Circuits	

Applications: Process Water, Ethylene Glycol (50%)

45 W/in ² Steel Tank 15-Incoloy® (7 W/cm ²)	30	6.1	CFPNF13G27	5			217 (99)
	37.5	6.1	CFPNF16A27	5			220 (100)
	45	6.1	CFPNF18G27	5			223 (102)
	60	6.1	CFPNF22R27	5	CFPNF22R28	5	226 (103)
	75	6.2	CFPNF27R27	5	CFPNF27R28	5	232 (106)
	90	6.2	CFPNF32R27	5	CFPNF32R28	5	236 (107)
	120	6.3			CFPNF42G28	5	304 (138)
	150	6.3			CFPNF51R28	5	314 (143)

Applications: Cooking Oils, Ethylene Glycol (100%)

30 W/in ² Steel Tank 15-Incoloy® (4.7 W/cm ²)	25	6.1	CFPNF16J12	5	CFPNF16J13	5	220 (100)
	32	6.1	CFPNF19J12	5	CFPNF19J13	5	223 (102)
	42	6.1	CFPNF24J12	5	CFPNF24J13	5	226 (103)
	52	6.2	CFPNF30A12	5	CFPNF30A13	5	232 (106)
	64	6.2	CFPNF35A12	5	CFPNF35A13	5	236 (107)
	85	6.3	CFPNF45J12	5	CFPNF45J13	5	304 (138)
	110	6.3			CFPNF56A13	5	314 (143)

Applications: Heat Transfer Oils, Mineral Oil, Degreasing Solutions

23 W/in ² Steel Tank 15-Incoloy® (3.6 W/cm ²)	19	6.1	CFPNF16J20	5			220 (100)
	24	6.1	CFPNF19J20	5			223 (102)
	32	6.1	CFPNF24J20	5	CFPNF24J19	5	226 (103)
	40	6.2	CFPNF30A20	5	CFPNF30A19	5	232 (106)
	48	6.2	CFPNF35A20	5	CFPNF35A19	5	236 (107)
	64	6.3	CFPNF45J20	5	CFPNF45J19	5	304 (138)
	80	6.3	CFPNF56A20	5	CFPNF56A19	5	314 (143)

Applications: Medium Weight Oils, Heat Transfer Oils, Lube Oils, Liquid Paraffin

15 W/in ² Steel Tank 15-Incoloy® (2.3 W/cm ²)	10	6.1	CFPNF13G29	5			217 (99)
	12.5	6.1	CFPNF16A29	5			220 (100)
	15	6.1	CFPNF18G29	5			223 (102)
	20	6.1	CFPNF22R29	5	CFPNF22R30	5	226 (103)
	25	6.2	CFPNF27R29	5	CFPNF27R30	5	232 (106)
	30	6.2	CFPNF32R29	5	CFPNF32R30	5	236 (107)
	40	6.3	CFPNF42G29	5	CFPNF42G30	5	304 (138)
	50	6.3	CFPNF51R29	5	CFPNF51R30	5	314 (143)

Applications: Bunker C and #6 Fuel Oils, Asphalt

8 W/in ² Steel Tank 15-Incoloy® (1.3 W/cm ²)	6.3	6.1	CFPNF16J22	5			220 (100)
	8.1	6.1	CFPNF19J22	5			223 (102)
	10.6	6.1	CFPNF24J22	5	CFPNF24J21	5	226 (103)
	13.1	6.2	CFPNF30A22	5	CFPNF30A21	5	232 (106)
	16	6.2	CFPNF35A22	5	CFPNF35A21	5	236 (107)
	21.3	6.3	CFPNF45J22	5	CFPNF45J21	5	304 (138)
	26	6.3	CFPNF56A22	5	CFPNF56A21	5	314 (143)

All circulation heaters are Assembly Stock unless otherwise noted.

③ Must be operated 3-phase wye only.

④ Wired for higher voltage.

Availability

Assembly Stock: Five to seven working days

Truck Shipment only

Tubular and Process Assemblies

Circulation Heaters

8" Flange

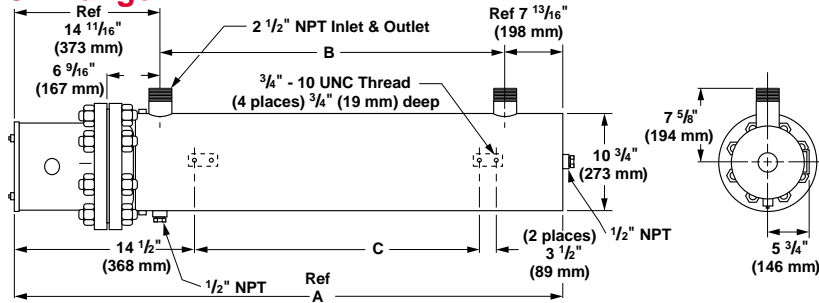

Fig. No.	A Dimension in (mm)	B Dimension in (mm)	C Dimension in (mm)
7.1	47 ¹ / ₁₆ (1199)	24 ¹ / ₁₆ (627)	21 ³ / ₁₆ (538)
7.2	55 ¹ / ₁₆ (1402)	32 ¹ / ₁₆ (830)	29 ¹ / ₁₆ (741)
7.3	62 ¹ / ₁₆ (1580)	39 ¹ / ₁₆ (1008)	36 ¹ / ₁₆ (919)
7.4	69 ¹ / ₁₆ (1773)	47 ¹ / ₁₆ (1202)	43 ¹ / ₁₆ (1113)
7.5	79 ¹ / ₁₆ (2014)	56 ¹ / ₁₆ (1443)	53 ¹ / ₁₆ (1354)
7.6	88 ¹ / ₁₆ (2243)	65 ¹ / ₁₆ (1672)	62 ¹ / ₁₆ (1583)
7.7	98 ¹ / ₁₆ (2497)	75 ¹ / ₁₆ (1926)	72 ¹ / ₁₆ (1837)

8" 150 lb ANSI Flange—WATROD Element

WATROD Description	kW	Fig. No.	Code No.								Est. Ship. Weight (kg)
			240V~(ac) 1-Phase	No. of Circuits	240V~(ac) 3-Phase	No. of Circuits	480V~(ac) 1-Phase	No. of Circuits	480V~(ac) 3-Phase	No. of Circuits	

Application: Clean Water

60 W/in ² Steel Tank 18-Copper (9.3 W/cm ²)	50	7.1			CFRC721N3②	3	CFRC721N11	3	CFRC721N5	2	340 (155)
	75	7.2			CFRC729N3②	6			CFRC729N5②	2	360 (164)
	100	7.3			CFRC737E3②	6			CFRC737E5	3	385 (175)
	125	7.4			CFRC745E3②	6			CFRC745E5②	3	410 (186)
	150	7.5							CFRC752N5②	6	440 (200)
	175	7.6							CFRC760N5②	6	465 (211)
	200	7.7							CFRC768E5②	6	510 (232)

Application: Process Water

48 W/in ² ⑤ Steel Tank 18-Incoloy® (7.5 W/cm ²)	50	7.2			CFRN725N3②	3	CFRN725N11②	3	CFRN725N5②	2	350 (159)
	75	7.3			CFRN735N3②	6			CFRN735N5②	2	380 (173)
	100	7.4			CFRN744E3	6			CFRN744E5	3	410 (186)
	125	7.5			CFRN754M3②	6			CFRN754M5②	6	445 (202)
	150	7.6							CFRN763M5②	6	490 (223)
	175	7.7							CFRN773D5	6	530 (241)
	200	7.7							CFRN782M5②	6	560 (254)
48 W/in ² Steel Tank 24-Incoloy® (7.5 W/cm ²)	67	7.2			CFRN726D3X②	4	CFRN726D11X②	3	CFRN726D5X②	2	358 (163)
	100	7.3			CFRN736D3X②	8			CFRN736D5X②	4	392 (178)
	133	7.4			CFRN744M3X②	8			CFRN744M5X②	4	425 (193)
	167	7.5			CFRN754M3X②	8			CFRN754M5X②	8	463 (210)
	200	7.6							CFRN763M5X②	8	511 (232)
	233	7.7							CFRN773D5X	8	554 (252)
	267	7.7							CFRN782M5X②	8	587 (267)

Applications: Forced Air and Gases, Caustic Solutions, Degreasing Solutions

23 W/in ² ⑤⑥ Steel Tank 18-Incoloy® (3.6 W/cm ²)	30	7.2	CFRNA32N10②	3	CFRNA32N3②	2	CFRNA32N11②	2	CFRNA32N5②	1	370 (168)
	40	7.3			CFRNA43E3②	3	CFRNA43E11②	2	CFRNA43E5②	2	410 (186)
	50	7.4			CFRNA51M3②	3	CFRNA51M11	3	CFRNA51M5	2	440 (200)
23 W/in ² Steel Tank 24-Incoloy® (3.6 W/cm ²)	40	7.2	CFRNA33D10X②	4	CFRNA33D3X②	4	CFRNA33D11X②	2	CFRNA33D5X②	2	382 (174)
	53	7.3			CFRNA43M3X②	4	CFRNA43M11X②	3	CFRNA43M5X②	2	425 (193)
	67	7.4			CFRNA51M3X②	4	CFRNA51M11X②	3	CFRNA51M5X②	2	457 (207)

CONTINUED

All circulation heaters are Assembly Stock unless otherwise noted.

Availability

Assembly Stock: Five to seven working days

Standard: 10 working days

Truck Shipment only

② Standard

⑤ 240V~(ac) can be wired wye and operated at 480V~(ac) 3-phase to produce 1/2 more kW and watt density.

⑥ Can be wired wye to produce 1/2 of the original kW and watt density (3-phase only).

Tubular and Process Assemblies

Circulation Heaters

8" 150 lb ANSI Flange—WATROD Element

WATROD Description	kW	Fig. No.	Code No.								Est. Ship.	
			240V~(ac) 1-Phase	No. of Circuits	240V~(ac) 3-Phase	No. of Circuits	480V~(ac) 1-Phase	No. of Circuits	480V~(ac) 3-Phase	No. of Circuits	Weight lbs	(kg)

Applications: Lightweight Oils, Degreasing Solutions, Heat Transfer Oils

23 W/in² Steel Tank 18-Steel (3.6 W/cm ²)	30.0	7.2	CFRS732N10 ^②	3	CFRS732N3 ^②	2	CFRS732N11 ^②	2	CFRS732N5 ^②	1	370 (168)
	40.0	7.3			CFRS743E3 ^②	3	CFRS743E11 ^②	2	CFRS743E5	2	410 (186)
	50.0	7.4			CFRS751M3	3	CFRS751M11	3	CFRS751M5	2	440 (200)
	60.0	7.5			CFRS762D3 ^②	6	CFRS762D11 ^②	3	CFRS762D5 ^②	2	480 (218)
	70.0	7.6			CFRS770M3 ^②	6	CFRS770M11	6	CFRS770M5	2	530 (241)
	80.0	7.7			CFRS779M3 ^②	6			CFRS779M5 ^②	3	610 (277)
23 W/in² Steel Tank 24-Steel (3.6 W/cm ²)	40.0	7.2	CFRS733D10X ^②	4	CFRS733D3X ^②	4	CFRS733D11X ^②	2	CFRS733D5X ^②	2	382 (174)
	53.0	7.3			CFRS743M3X ^②	4	CFRS743M11X ^②	3	CFRS743M5X ^②	2	425 (193)
	67.0	7.4			CFRS751M3X ^②	4	CFRS751M11X ^②	3	CFRS751M5X ^②	2	457 (208)
	80.0	7.5			CFRS762D3X ^②	8	CFRS762D11X ^②	4	CFRS762D5X ^②	4	461 (209)
	93.0	7.6			CFRS770M3X ^②	8	CFRS770M11X ^②	6	CFRS770M5X ^②	4	554 (252)
	107.0	7.7			CFRS779M3X ^②	8			CFRS779M5X ^②	4	636 (289)

Applications: Medium Weight Oils, Heat Transfer Oils, Liquid Paraffin

16 W/in² Steel Tank 18-Incoloy [®] (2.6 W/cm ²)	17.0	7.2			CFRN725N12 ^②	1			CFRN725N13 ^②	1	350 (159)
	25.0	7.3			CFRN735N12 ^②	2			CFRN735N13 ^②	1	380 (173)
	33.0	7.4			CFRN744E12 ^②	2			CFRN744E13	1	410 (186)
	42.0	7.5			CFRN754M12 ^②	3			CFRN754M13 ^②	2	445 (202)
	50.0	7.6							CFRN763M13 ^②	2	490 (223)
	58.0	7.7							CFRN773D13	2	530 (241)
67.0	7.7			CFRN782M13 ^②	2	560 (254)					
16 W/in² Steel Tank 24-Incoloy [®] (2.6 W/cm ²)	23.0	7.2			CFRN726D12X ^②	2			CFRN726D13X ^②	1	358 (163)
	33.0	7.3			CFRN736D12X ^②	2			CFRN736D13X ^②	1	392 (178)
	44.0	7.4			CFRN744M12X ^②	4			CFRN744M13X ^②	2	425 (193)
	56.0	7.5			CFRN754M12X ^②	4			CFRN754M13X ^②	2	463 (210)
	67.0	7.6							CFRN763M13X ^②	2	511 (232)
	77.0	7.7							CFRN773D13X ^②	2	554 (252)
89.0	7.7			CFRN782M13X ^②	4	587 (267)					

Applications: Bunker C and #6 Fuel Oils

8 W/in² Steel Tank 18-Steel (1.3 W/cm ²)	12.5	7.3			CFRS743E12 ^②	1			CFRS743E13 ^②	1	410 (186)
	16.5	7.4			CFRS751M12	1			CFRS751M13	1	440 (200)
	20.0	7.5			CFRS762D12 ^②	2			CFRS762D13 ^②	1	480 (218)
	24.0	7.6			CFRS770M12	2			CFRS770M13	1	530 (241)
	27.0	7.7			CFRS779M12 ^②	2			CFRS779M13 ^②	1	610 (277)
8 W/in² Steel Tank 24-Steel (1.3 W/cm ²)	17.0	7.3			CFRS743M12X ^②	1			CFRS743M13X ^②	1	425 (193)
	22.0	7.4			CFRS751M12X ^②	2			CFRS751M13X ^②	1	457 (208)
	27.0	7.5			CFRS762D12X ^②	2			CFRS762D13X ^②	1	461 (209)
	32.0	7.6			CFRS770M12X ^②	2			CFRS770M13X ^②	1	554 (252)
	36.0	7.7			CFRS779M12X ^②	2			CFRS779M13X ^②	1	636 (289)

All circulation heaters are Assembly Stock unless otherwise noted.

② Standard

③ Must be operated 3-phase wye only.

Availability

Assembly Stock: Five to seven working days

Standard: 10 working days

Truck Shipment only

Tubular and Process Assemblies

Circulation Heaters

10" Flange

Fig. No.	A Dimension in (mm)	B Dimension in (mm)	C Dimension in (mm)
8.1	76 ⁵ / ₁₆ (1945)	60 ¹ / ₁₆ (1545)	67 ⁵ / ₁₆ (1716)
8.2	84 ¹ / ₁₆ (2135)	68 ⁵ / ₁₆ (1735)	75 ¹ / ₁₆ (1907)
8.3	91 ³ / ₁₆ (2316)	75 ¹ / ₁₆ (1916)	82 ³ / ₁₆ (2088)
8.4	99 ¹ / ₁₆ (2516)	83 ⁵ / ₁₆ (2116)	90 ¹ / ₁₆ (2288)
8.5	106 ⁷ / ₁₆ (2707)	90 ¹ / ₁₆ (2307)	97 ⁷ / ₁₆ (2478)

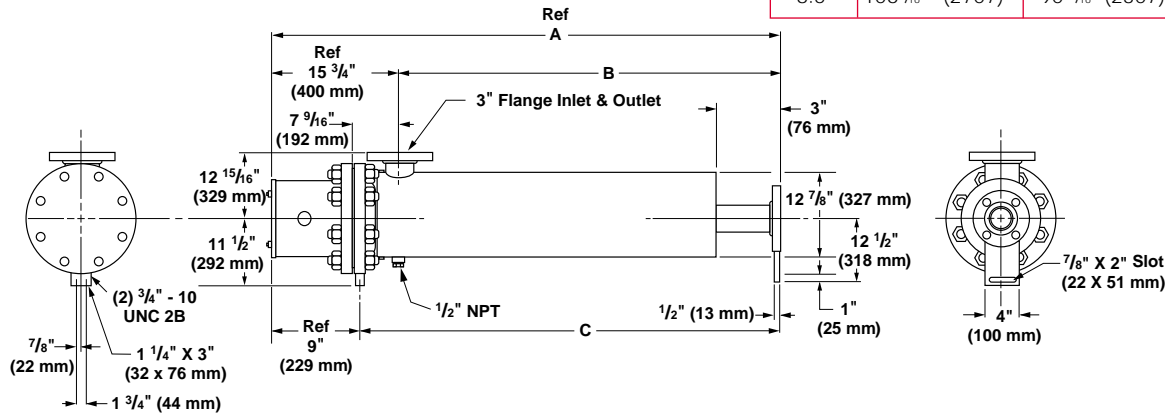

10" 150 lb ANSI Flange—WATROD Element

WATROD Description	kW	Fig. No.	Code No.				Est. Ship.	
			240V~(ac) 3-Phase	No. of Circuits	480V~(ac) 3-Phase	No. of Circuits	Weight lbs (kg)	

Application: Process Water

48 W/in ² ⑤ Steel Tank 27-Incoloy® (7.5 W/cm ²)	262	8.5			CFSSN773E5	9	600 (273)
---	-----	-----	--	--	------------	---	-----------

Applications: Forced Air and Gases, Caustic Solutions, Degreasing Solutions

23 W/in ² ⑤⑥ Steel Tank 27-Incoloy® (3.6 W/cm ²)	60	8.1	CFSNA43N3②	3	CFSNA43N5②	3	515 (234)
	75	8.2	CFSNA51N3②	9	CFSNA51N5	3	530 (241)

Applications: Lightweight Oils, Degreasing Solutions, Heat Transfer Oils

23 W/in ² Steel Tank 27-Steel (3.6 W/cm ²)	90	8.3			CFSS762E5②	3	540 (245)
	105	8.4			CFSS770N5	3	600 (272)
	120	8.5			CFSS778N5②	3	645 (293)

Applications: Medium Weight Oils, Heat Transfer Oils, Liquid Paraffin

16 W/in ² ③ Steel Tank 27-Incoloy® (2.6 W/cm ²)	75	8.3			CFSN763N13②	3	540 (245)
	87	8.5			CFSN773E13②	3	600 (273)

Applications: Bunker C and #6 Fuel Oils

8 W/in ² ③ Steel Tank 27-Steel (1.3 W/cm ²)	30	8.3	CFSS762E12②	3	CFSS762E13②	1	540 (245)
	35	8.4	CFSS770N12	3	CFSS770N13	1	600 (273)
	40	8.5	CFSS778N12②	3	CFSS778N13②	1	645 (293)

All circulation heaters are Assembly Stock unless otherwise noted.

Availability

Assembly Stock: Five to seven working days

Standard: 10 working days

■ Truck Shipment only

② Standard

③ Must be operated 3-phase wye only.

⑤ 240V~(ac) can be wired wye and operated at 480V~(ac) 3-phase to produce 1/2 more kW and watt density.

⑥ Can be wired wye to produce 1/2 of the original kW and watt density (3-phase only).

Tubular and Process Assemblies

Circulation Heaters 12" Flange

Fig. No.	A Dimension in (mm)	B Dimension in (mm)	C Dimension in (mm)
9.1	76 1/8 (1953)	60 1/16 (1541)	67 13/16 (1722)
9.2	84 3/8 (2143)	68 3/16 (1732)	75 5/16 (1913)
9.3	91 1/8 (2334)	75 11/16 (1922)	82 13/16 (2103)
9.4	99 (2515)	82 13/16 (2103)	89 15/16 (2284)
9.5	106 1/2 (2705)	90 5/16 (2294)	97 1/16 (2475)

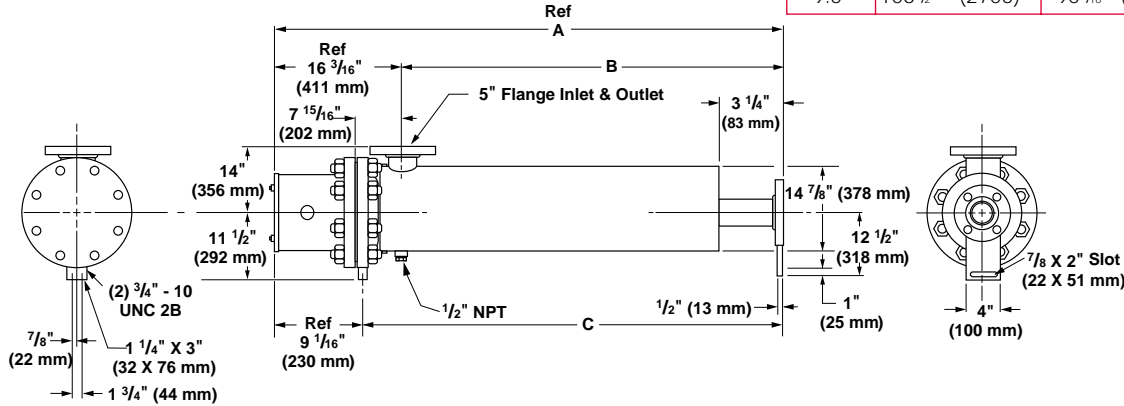

Circulation Heaters

12" 150 lb ANSI Flange—WATROD Element

WATROD Description	kW	Fig. No.	Code No.				Est. Ship.	
			240V~(ac) 3-Phase	No. of Circuits	480V~(ac) 3-Phase	No. of Circuits	Weight lbs	(kg)

Application: Process Water

48 W/in ² Steel Tank 36-Incoloy® (7.5 W/in ²)	350	9.5			CFTN773C5	12	650 (295)
--	-----	-----	--	--	-----------	----	-----------

Applications: Forced Air and Gases, Caustic Solutions, Degreasing Solutions

23 W/in ² Steel Tank 36-Incoloy® (3.6 W/cm ²)	80	9.1			CFTNA43L5②	3	565 (257)
	100	9.2			CFTNA51L5	3	585 (266)

Applications: Lightweight Oils, Degreasing Solutions, Heat Transfer Oils

23 W/in ² Steel Tank 36-Steel (3.6 W/cm ²)	140	9.4			CFTS770L5	4	650 (295)
	160	9.5			CFTS778L5②	4	700 (318)

Applications: Medium Weight Oils, Heat Transfer Oils, Liquid Paraffin

16 W/in ² ③ Steel Tank 36-Incoloy® (2.6 W/cm ²)	117	9.5			CFTN773C13②	3	650 (295)
--	-----	-----	--	--	-------------	---	-----------

Applications: Bunker C and #6 Fuel Oils

8 W/in ² ③ Steel Tank 36-Steel (1.3 W/cm ²)	47	9.4	CFTS770L12②	3	CFTS770L13	2	700 (318)
	54	9.5	CFTS778L12②	3	CFTS778L13②	2	750 (341)

All circulation heaters are Assembly Stock unless otherwise noted.

Availability

Assembly Stock: Five to seven working days

Standard: 10 working days

■ Truck Shipment only

② Standard

③ Must be operated 3-phase wye only.

Tubular and Process Assemblies

Circulation Heaters

14" Flange

Fig. No.	A Dimension in (mm)	B Dimension in (mm)	C Dimension in (mm)
10.1	75 3/4 (1924)	59 7/16 (1510)	66 1/2 (1689)
10.2	83 1/4 (2115)	66 15/16 (1700)	74 (1880)
10.3	90 3/4 (2305)	74 7/16 (1891)	81 1/2 (2070)
10.4	98 1/4 (2496)	81 15/16 (2081)	89 (2261)
10.5	105 3/4 (2686)	89 7/16 (2272)	96 1/2 (2451)

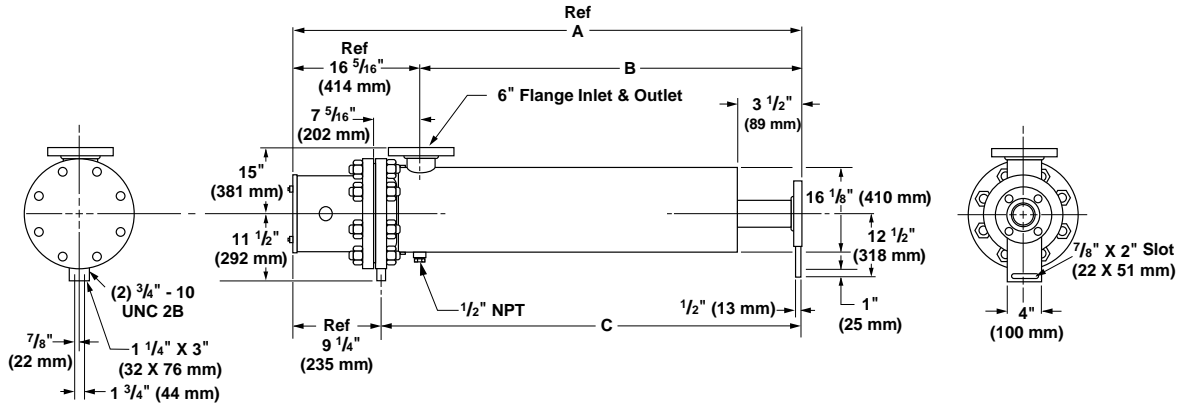

14" 150 lb ANSI Flange—WATROD Element

WATROD Description	kW	Fig. No.	Code No.				Est. Ship.	
			240V~(ac) 3-Phase	No. of Circuits	480V~(ac) 3-Phase	No. of Circuits	Weight lbs	(kg)

Application: Process Water

48 W/in ² Steel Tank	315	10.2			CFWN754J5②	15	600 (273)
45-Incoloy® (7.5 W/cm ²)	375	10.3			CFWN763J5②	15	650 (295)

Applications: Forced Air and Gases, Caustic Solutions, Degreasing Solutions

23 W/in ² Steel Tank	100	10.1			CFWNA43J5②	3	570 (259)
45-Incoloy® (3.6 W/cm ²)	125	10.2			CFWNA51J5	5	590 (268)

Applications: Lightweight Oils, Degreasing Solutions, Heat Transfer Oils

23 W/in ² Steel Tank	150	10.3			CFWS762A5②	5	650 (295)
45-Steel (3.6 W/cm ²)	175	10.4			CFWS770J5	5	700 (318)
	200	10.5			CFWS778J5②	5	780 (354)

Applications: Medium Weight Oils, Heat Transfer Oils, Liquid Paraffin

16 W/in ² Steel Tank	105	10.2			CFWN754J13②	3	600 (273)
45-Incoloy® (2.6 W/cm ²)	125	10.3			CFWN763J13②	5	650 (295)

Applications: Bunker C and #6 Fuel Oils

8 W/in ² Steel Tank	60	10.4	CFWS770J12②	3	CFWS770J13	3	700 (318)
45-Steel (1.3 W/cm ²)	67	10.5	CFWS778J12②	5	CFWS778J13②	3	780 (354)

All circulation heaters are Assembly Stock unless otherwise noted.

Availability

Assembly Stock: Five to seven working days

Standard: 10 working days

Truck Shipment only

② Standard

③ Must be operated 3-phase wye only.

Tubular and Process Assemblies

F.O.B.: Hannibal, Missouri

Circulation Heaters

Build-a-Code

Circulation Heater Base Code Number _____

General purpose (NEMA 1) terminal enclosure standard

Optional Terminal Enclosure Type _____

- S** = General purpose with thermostat (NEMA 1)
- W** = Moisture resistant (NEMA 4)
- E** = Explosion resistant (NEMA 7)
- E/W** = Explosion/moisture resistant (NEMA 7/4)

Optional Thermostat^① or Thermocouple^② _____

- ① Thermostat code numbers shown on [page 425](#). Check sensing bulb O.D. against thermowell I.D. to assure proper fit. For side-mount thermostats, also assure adequate capillary tube length.
- ② Specify Type J or K thermocouple. If overtemp thermocouple specify orientation horizontal, vertical up or vertical down.

Circulation Heaters

How to Order

To order a stock circulation heater, please specify:

- Watlow code number
- Volts/watts
- Phase
- Flange or screw plug size
- Tank material
- Options
- Quantity

If the circulation heater is to be configured with options, add the suffix letter(s) to the circulation heater base code number, as indicated on the Build-a-Code chart.

If stock units do not meet your application needs, Watlow can provide **made-to-order** heaters. Please provide:

- Application (including vessel orientation)
- Volts/watts
- Phase
- Number of circuits
- Watt density
- Sheath material and number of heating elements
- Flange or screw plug size
- Tank material
- Inlet and outlet mating type and size
- Centerline of inlet and outlet
- Terminal enclosure type
- Options
- Quantity

Availability

Assembly Stock: Five to seven working days

Modified Stock[Ⓢ]: Five-10 working days

Standard: 10 working days

Made-to-Order: Six to eight weeks

Options, complexity and quantity may affect availability and lead times. Consult factory.

Replacement Heater Assemblies Only

Replacement heater assemblies available by ordering circulation heater code number and specifying "replacement heater only."

[Ⓢ] Assembly Stock units with catalog options.

Tubular and Process Assemblies

Circulation Heaters

Booster Heaters

Booster Heaters

Booster heaters are ideal for circulating applications requiring less kilowatts, including engine preheating.

Booster heaters are made from a steel or brass 1¼" NPT screw plug heater and insulated pressure vessel with 1" FNPT inlet and outlet. This assembly also contains an integral thermostat.

Performance Capabilities

- Watt densities to 60 W/in² (9.3 W/cm²)
- Wattages to 3kW
- Voltages to 480V~(ac)
- Steel sheath temperatures to 750°F (400°C)
- Copper sheath temperatures to 350°F (175°C)

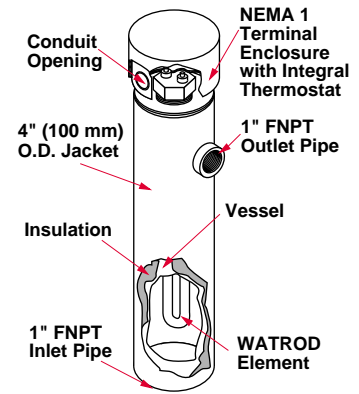

Features and Benefits

- **Dual voltages** simplify stocking and wiring.
- **Carbon steel, standard pipe wall vessel** is compatible with many applications.
- **One inch thick (25 mm) fiberglass thermal insulation**, rated to 750°F (400°C), reduces heat loss.
- **Steel jacket (shroud)** is fully welded and painted to protect thermal insulation.
- **Inlet and outlet nozzle connections** are one inch FNPT fittings welded to the vessel.
- **General purpose (NEMA 1) terminal enclosure** protects terminals and thermostat.
- **Integral thermostat controls** process temperatures from:
60° to 160°F (15° to 70°C) on copper sheath elements
175° to 550°F (80° to 290°C) on steel sheath elements

Applications

- Stand by generators
- Peak power trimming generators
- Mobile generator sets
- Earth-moving equipment
- Water heaters
- Lightweight oils

Options

Terminal Enclosure

General purpose (NEMA 1) terminal enclosures with integral thermostats are supplied on all Watlow booster heaters. Optional moisture resistant (NEMA 4) terminal enclosures

protect wiring and thermostat from liquid contaminants. To order, add the suffix letter **W** to the booster heater base code number.

For explosion resistant (NEMA 7) and explosion/moisture resistant (NEMA 7/4) terminal enclosures, see **Screw Plug Immersion Heaters, pages 322 to 324.**

Tubular and Process Assemblies

F.O.B.: Hannibal, Missouri

Circulation Heaters Booster Heaters

Description	kW	Phase	Code No. 120/240V~(ac)	Est. Ship. Weight lbs (kg)
-------------	----	-------	---------------------------	-------------------------------

Application: Aqueous Solutions

60 W/in ²	1.5	1	CBEC8G6	18 (8.2)
Brass Plug	2.0	1	CBEC10F6	18 (8.2)
2-Copper (9.3 W/cm ²)	2.5	1	CBEC12F6	18 (8.2)
	3.0	1	CBEC15A6X	18 (8.2)

Application: Lightweight Oils

23 W/in ²	0.5	1	CBES7G6	18 (8.2)
Steel Plug	0.75	1	CBES10B6	18 (8.2)
2- Steel (3.6 W/cm ²)	1.0	1	CBES12P6	18 (8.2)

All units are Assembly Stock

For optional housing adders use circulation heater adders.

Availability

Assembly Stock: Five to seven days

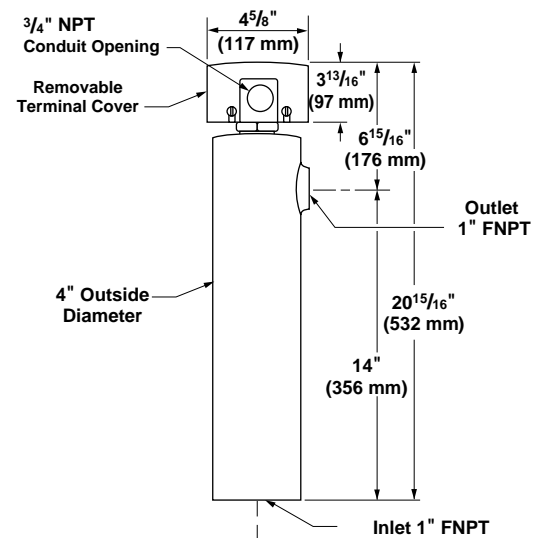

Circulation Heaters

How to Order

To order a booster heater, please specify:

- Watlow code number
- Volts/watts
- Options
- Quantity

If the booster heater requires an optional NEMA 4 terminal enclosure, add the suffix letter **W** to the base code number.

If our Assembly Stock units do not meet your application needs, Watlow can provide a made-to-order unit. For **made-to-order** units, consult your Watlow representative and provide the following information:

- Application
- Volts/watts
- Watt density
- Phase
- Terminal enclosure type
- Options
- Quantity

Availability

Assembly Stock: Five to seven working days

Modified StockⓈ: Five to seven working days

Made-to-Order: Six to eight weeks

Options, complexity and quantity may affect availability and lead times. Consult factory.

Ⓢ Assembly Stock units with catalog options.

Tubular and Process Assemblies

Circulation Heaters

Engine Preheaters

Watlow engine preheaters help maintain a desired minimum engine temperature to make starting fast and easy. Also reduces engine wear caused by cold engine starting.

Engine preheaters mount conveniently on an engine or rail. The internal thermostat constantly adjusts to ambient temperature changes to keep engine coolant warm at all times.

An internal tank temperature sensor protects Watlow engine preheaters from dry fire conditions caused by low coolant levels or blocked flow.

Installation is easy with just two mounting bolts, and inlet and outlet hose connections.

Performance Capabilities

- Watt densities from 45 to 90 W/in² (7 to 14 W/cm²)
- Up to 6 kW
- UL® and CSA component recognition to 480V~(ac) and 600V~(ac) respectively.
- Thermostatically controlled from 60 to 160°F (15 to 70°C)
- Incoloy® sheath temperatures to 1600°F (870°C)

Features and Benefits

- **Incoloy® sheath** minimizes the risk of premature failure in the event of a dry-fire condition.
- **Integral, prewired adjustable thermostat**, mounted in a general purpose (NEMA 1) terminal enclosure provides a ready-to-install unit.
- **Easy installation with standard, one inch (25 mm) diameter beaded inlet and outlet nozzles.** Rubber hose connections eliminate the need for threaded fittings and adapters.
- **120/240V~(ac) or 240/480V~(ac) dual voltages** make field wiring flexible. Minimizes stocking multiple voltages.
- **Mounting bracket** isolates harmful engine vibration.
- **Heavy-duty welded carbon steel tank** resists corrosion and extends life.
- **Optional oil pressure interconnect switch** disrupts power during engine operation.



- **Integral check valve** assures proper coolant flow and correct thermostat operation. Check valve will not interfere with adequate thermo-siphoning.
- **UL® and CSA component** recognition under file numbers E52951 and 31388 respectively. See **pages 268 to 271** for details.

Applications

- Standby generators
- Primary power generators
- Firepump engines

Options

Terminal Enclosures

The following terminal enclosures are available:

- Standard, general purpose (NEMA 1)
- Moisture resistant (NEMA 4)

- Explosion resistant (NEMA 7) class 1, groups C and D. For class 1, group B enclosures, consult your Watlow representative.

Order by adding the suffix letter **W** (NEMA 4) or **E** (NEMA 7) to the engine preheater base code number.

Threaded Nozzles

Carbon steel threaded inlets and outlets are available for installations using rigid piping or threaded adapters. Threaded nozzles are

typically supplied for firepump applications. To order, specify **threaded nozzles** and **NPT size**.

Tubular and Process Assemblies

F.O.B.: Hannibal, Missouri

Circulation Heaters

Engine Preheaters

Application Hints

- Mount engine preheaters in horizontal position only (as shown in Figures #1, #2 and #3). Consult your Watlow representative if vertical mounting is unavoidable.
- Mount the heater near or below the lowest point on the engine block. Keep outlet nozzle pointed up, as indicated on the tank.
- Estimate kilowatt requirements with the following formula. First determine the engine displacement, then multiply:

English
Cubic inches X 3 = estimated wattage

Metric
Liters X 183 = estimated wattage

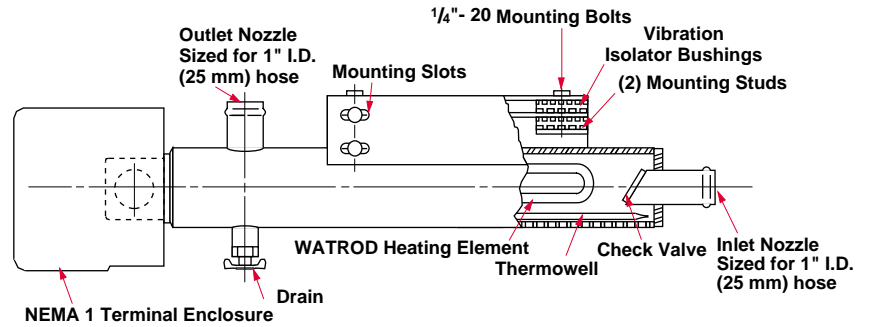
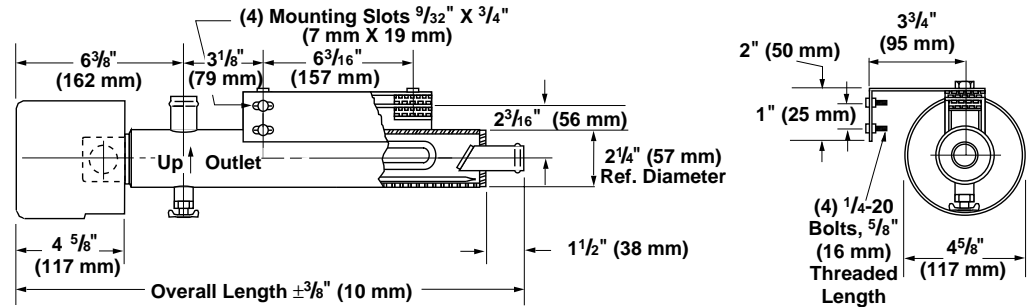

Figure 1



kW	Overall Length Inch (mm)	Code No.			Est. Ship.	
		120/240V~(ac) 1-Phase	208V~(ac) 1-Phase	240/480V~(ac) 1-Phase	Weight lbs	(kg)

Application: Ethylene Glycol/Engine Coolant

1.13	20 7/8 (530)	CPBPB6S12	CPBPL2S12①		12 (6)
1.50	20 7/8 (530)		CPBPB2S12①		12 (6)
1.69	20 7/8 (530)		CPBPM2S12①		12 (6)
1.88	20 7/8 (530)		CPBPN2S12①		12 (6)
2.00	20 7/8 (530)	CPBPC6S12			12 (6)
2.25	20 7/8 (530)	CPBPD6S12			12 (6)
2.25	26 1 1/8 (678)		CPBPD2S12①		15 (7)
2.50	20 7/8 (530)	CPBPE6S12			12 (6)
3.00	26 1 1/8 (678)		CPBPF2S12①	CPBPF7S12	15 (7)
3.75	26 1 1/8 (678)		CPBPG2S12①		15 (7)
4.00	26 1 1/8 (678)			CPBPH7S12	15 (7)
5.00	26 1 1/8 (678)			CPBPJ7S12①	15 (7)

All preheaters are Stock unless otherwise noted.

① Standard

Availability

Stock: Same day shipment

Standard: Four weeks

Tubular and Process Assemblies

F.O.B.: Hannibal, Missouri

Circulation Heaters Engine Preheaters

Figure 2

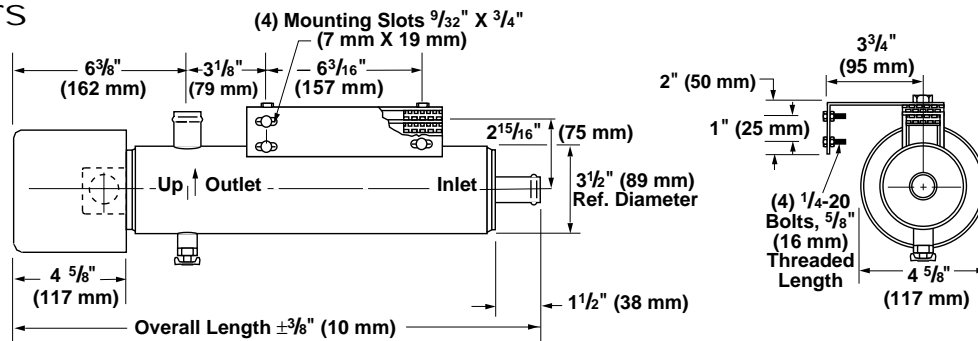

kW	Overall Length Inch (mm)	Code No.		Est. Ship. Weight lbs (kg)
		277V~(ac) 1-Phase	480V~(ac) 3-Phase	

Application: Ethylene Glycol/Engine Coolant

1.5	20% (530)	CPCPB4S12 [Ⓢ]	CPCPB13S12 [Ⓢ]	12 (6)
2.0	20% (530)	CPCPC4S12 [Ⓢ]	CPCPC13S12 [Ⓢ]	12 (6)
2.5	20% (530)	CPCPE4S12 [Ⓢ]	CPCPE13S12 [Ⓢ]	12 (6)
3.75	20% (530)	CPCPG4S12 [Ⓢ]	CPCPG13S12 [Ⓢ]	12 (6)
4.0	20% (530)	CPCPH4S12 [Ⓢ]	CPCPH13S12	12 (6)
5.0	20% (530)	CPCPJ4S12 [Ⓢ]	CPCPJ13S12	12 (6)

Figure 3

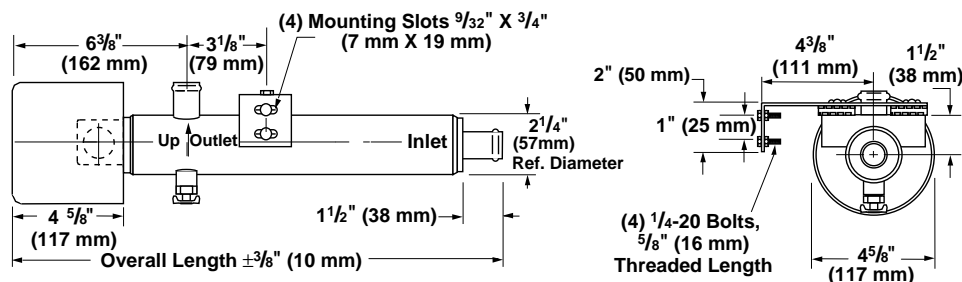

kW	Overall Length Inch (mm)	Code No.		Est. Ship. Weight lbs (kg)
		120/240V~(ac) 1-Phase	208V~(ac) 1-Phase	

Application: Ethylene Glycol/Engine Coolant

0.75	15% (397)		CPBPK2S12 [Ⓢ]	9 (4)
1.0	15% (397)	CPBPA6S12 [Ⓢ]		9 (4)

All preheaters are stock unless otherwise noted.

Availability

Stock: Same day shipment

Standard: Four weeks

Ⓢ Standard

How to Order

To order a Stock, or Standard engine preheater, please specify:

- Code number
- Volts/watts
- Phase
- Options
- Quantity

If our Stock units do not meet your application needs, Watlow will

provide a made-to-order unit. For **made-to-order** units, provide the following information:

- Volts/watts
- Phase
- Inlet and outlet type and size
- Terminal enclosure type
- Mounting orientation
- Options
- Quantity

Availability

Stock: Same day shipment

Modified StockⓈ: Five to seven working days

Standard: Four weeks

Made-to-Order: Six to eight weeks

Options, complexity and quantity may affect availability and lead times. Consult factory.

Ⓢ Stock units with catalog options.

Tubular and Process Assemblies

Circulation Heaters

Pipe Insert Heaters

Pipe insert immersion heaters permit removing and servicing the heater bundle without draining the liquid being heated.

Heating is accomplished by mounting a flange or screw plug immersion heater inside a pressure-tight bayonet pipe vessel. The pipe vessel then mates to a flange connection on a storage tank's side. Heat transfer between element(s) and tank contents is accomplished by heating the air or heat transfer fluid inside the bayonet pipe for conduction to the tank's contents.

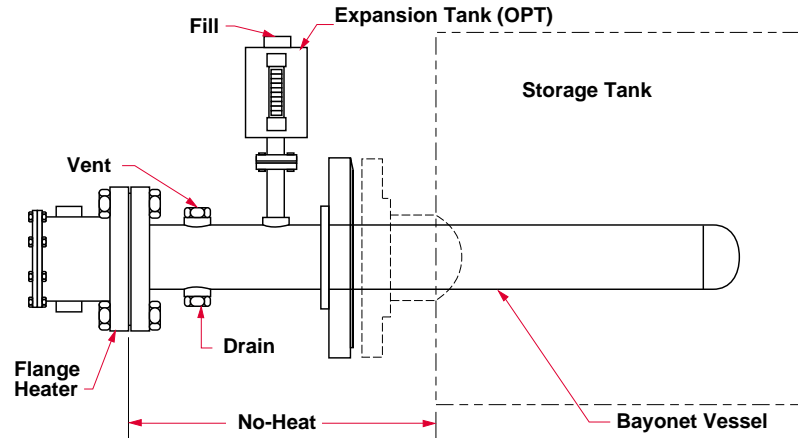

Performance Capabilities

- Wattages to 100kW
- Voltages to 600V~(ac)
- Ratings to 600 lb pressure class
- Incoloy® sheath temperatures to 1400°F (760°C)
- Stainless steel sheath temperatures to 1200°F (650°C)
- Steel sheath temperatures to 750°F (400°C)

Features and Benefits

- **Low watt density screw plug or flange heaters**, mounted in the bayonet vessel, provide long life.

- **Carbon steel, 304 and 316 stainless steel bayonet vessels** offer compatibility with a wide range of liquids.
- **Welded flange on pipe vessel** ensures pressure seal.
- **Heating element support(s)** ensure proper element spacing and maximum heater performance.
- **Heat transfer fluid fill/drain and vent couplings** ease installation and maintenance.

Applications

- Indirect heating of viscous fluids:
 - Asphalt
 - Tar
 - Molasses
 - Syrup
 - Glue
- Corrosive liquids
- Degreasing fluids

Options

Pipe insert heaters can be supplied with a variety of options, including:

- Appropriate gasket materials
- Passivation cleaning on pipe insert
- European screw plug to flange adapters

- CSA certified terminal enclosures
- Stand-off terminal enclosures
- Thermocouple temperature sensors
- Thermostats
- Customer specified materials, sizes and pressure class ratings

For descriptions and ordering information about these options, please refer to **Flange Immersion Heaters, pages 340 to 343**, or **Screw Plug Immersion Heaters, pages 322 to 326**.

Flanges

Flanges to 24 inches nominal pipe size are available in materials compatible with specific application

needs. For information on flange materials and ratings, consult your Watlow representative.

Circulation Heaters Pipe Insert Heaters

Bayonet Vessels

Bayonet vessels are available up to 14 inches nominal pipe size and 20 feet long. Vessel size is dependent upon the kW

requirement and element watt density. For more information, please consult your Watlow representative.

Application Hints

- Mount pipe insert heater horizontally.
- Locate pipe insert heaters low in the tank, but above the sludge level.
- Consider a low liquid level sensor to protect against low liquid level conditions.
- Select the proper heat transfer media (air or fluid) to adequately

conduct heat from the elements to the bayonet vessel. Consult your Watlow representative for recommendations.

- Select a watt density that's compatible with the heat transfer media being used.
- Use a sheath high-limit sensing device inside the bayonet vessel to protect against element over-heating.

- For pipe insert heater assemblies employing heat transfer fluid, use an expansion tank. This will allow for fluid expansion and contraction during heater cycling.
- Insulate the pipe insert heater's exterior to minimize heat loss.



Caution:

Do not insulate the terminal enclosure.

How to Order

All pipe insert heaters are **made-to-order**. To order, please specify:

- Application
- Volts/watts
- Phase
- Number of circuits
- Bayonet vessel material
- Storage tank mating flange size

- Maximum bayonet length beyond the storage tank mating flange
- Dimension from heater flange to inside of storage tank wall
- Terminal enclosure type
- Options
- Quantity

Availability

Made-to-Order: Six to eight weeks
Options, complexity and quantity may affect availability and lead times. Consult factory.